

PHANTOM PANTRY

Technical
Specifications &
Ordering Guide



The Phantom Pantry is a dream combination of quality and functionality. Suitable for everyday kitchen use, the design of the Phantom Pantry offers an aesthetic you desire and the practicality to increase your usable space and improve the ease of accessing stored goods. Offer your customers the very best in pull-out pantry shelving available today.

PRODUCT FEATURES

- Suitable for 500 or 600mm (20 or 24") wide cabinets
- Install cabinet door with 165 degree hinges
- Glass or walnut wood baskets both available
- Order total of 4, 5 or 6 baskets for short, medium or tall frames
- Anti-Slip Dark Grey Bottom Matting
- Load capacity: 70kg (154lbs)



MARATHON

Order Information



Phantom Pantry Frame Kit - Ordering Guide

Description	Part#
Phantom Pantry Kit 1420-1720mm (55 5/16"-67 3/4")	041-205105-1-3
Phantom Pantry Kit 1720-2020mm (67 3/4"-79 1/2")	041-205106-1-3
Phantom Pantry Kit 2020-2320mm (79 1/2"-91 5/16")	041-205107-1-3

Phantom Pantry Baskets - Glass/Dark Grey

Cabinet Width	Basket Width	Part#	Set/Box
500mm (20")	380mm (14 15/16")	041-205106-2-2-GL	2
500mm (20")	380mm (14 15/16")	041-205106-2-3-GL	3
600mm (24")	480mm (18 7/8")	041-205116-2-2-GL	2
600mm (24")	480mm (18 7/8")	041-205116-2-3-GL	3

Phantom Pantry Baskets - Walnut/Dark Grey

Cabinet Width	Basket Width	Part#	Set/Box
500mm (20")	380mm (14 15/16")	041-205162-2-2-WL	2
500mm (20")	380mm (14 15/16")	041-205162-2-3-WL	3
600mm (24")	480mm (18 7/8")	041-205166-2-2-WL	2
600mm (24")	480mm (18 7/8")	041-205166-2-3-WL	3

Technical Specifications

Height
 1420 - 2320 mm (55 5/16" - 91 5/16")

468 - 568mm (18 5/16" - 22 3/8")

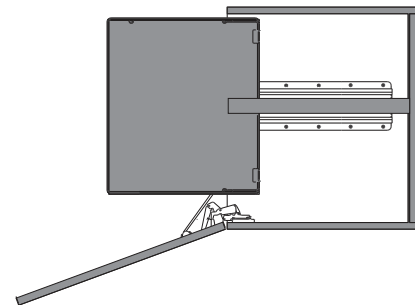
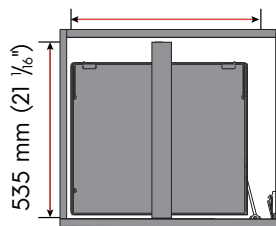

For more information on **Pantry Systems**, please contact your Sales Representative or visit us at marathonhardware.com

