

DF10 Undermount

Technical Specifications & Assembly

DF10 Undermount



Product Features

- Push-open
- 4-way clip provides height and lateral side adjustment
- Height adjustment (0-3mm)
- Lateral side adjustment (± 1.5 mm)
- Optional: 6-way clip enables depth adjustment (0-3mm)
- Tool free assembly and removal of drawer.
- Dynamic Load Capacity of 40kg (88lbs)

DF10 Undermount (Individual Parts)

- Includes 1 set of undermount slides
- All DTC slides include front 4-Way locking clips.
- Screw kit
- Push-open synchronization rod

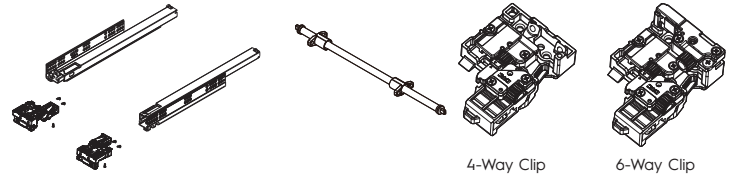

DF10 Undermount Ordering Guide

Length (mm/Inch)	Matte Grey	Set/Box
250mm (10")	105-DF10-250H	6
300mm (12")	105-DF10-300H	6
350mm (14")	105-DF10-350H	6
400mm (16")	105-DF10-400H	6
450mm (18")	105-DF10-450H	6
500mm (20")	105-DF10-500H	6
550mm (22")	105-DF10-550H	6
600mm (24")	105-DF10-600H	6

DF10 Undermount Locking Clips Ordering Guide

Description	Part#	Set/Box
4-Way Adjustable locking clips	105-ODSD4-DS10H	50
6-Way Adjustable locking clips	105-ODSD6-DS10H	50

DF10 Undermount synchronization rod Ordering Guide(Sell separately)

Description	Part#	Set/Box
Synchronization rod	105-HT0FH02	50



Space Requirements

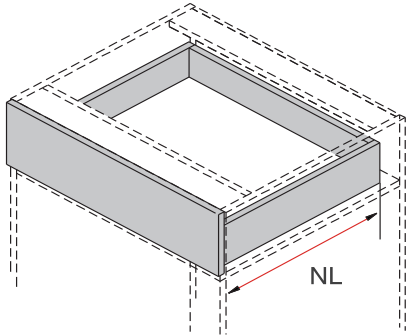

NL: Nominal length

Overlay Installation Dimensions

NL=Nominal Slide Length
LT =Internal Cabinet Depth
LT=NL + 3

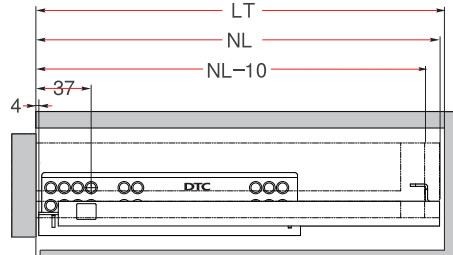

Inset Installation Dimensions

NL=Nominal Slide Length
LT =Internal Cabinet Depth
LT=NL + 3

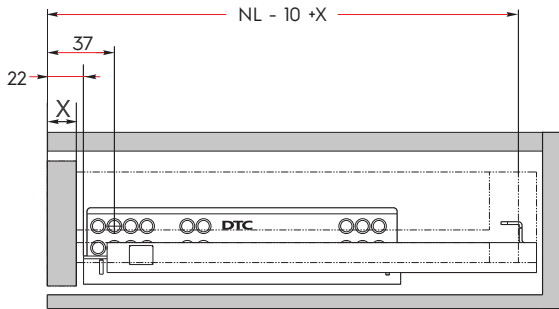

Drilling Pattern

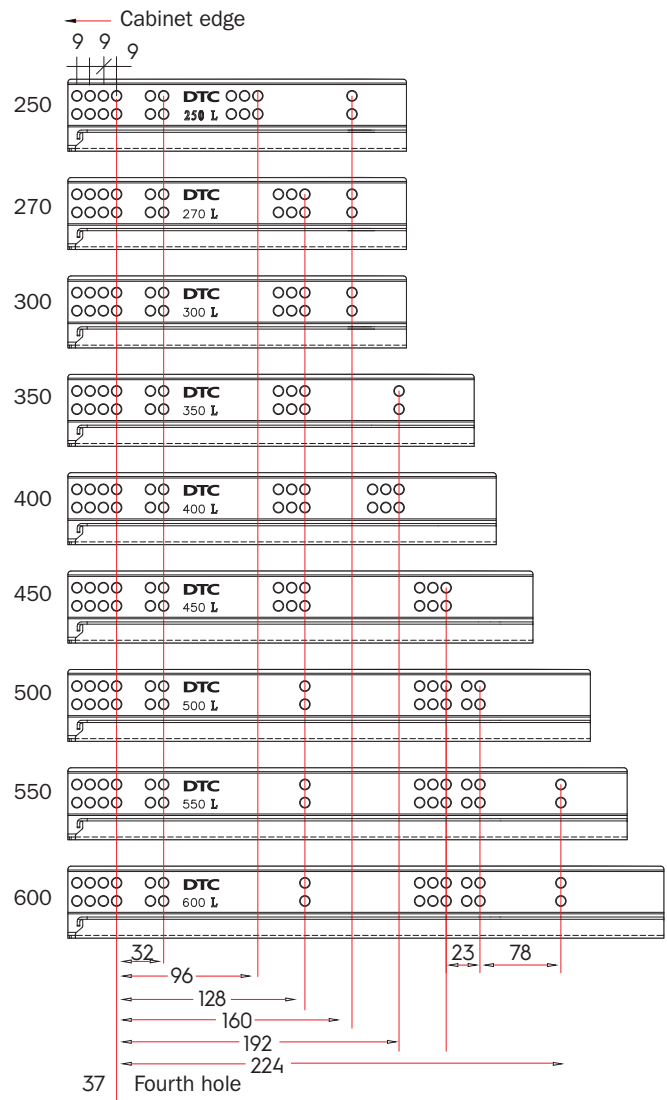

Installation Dimensions

SKW = Internal Drawer Width
LW = Internal Cabinet Width

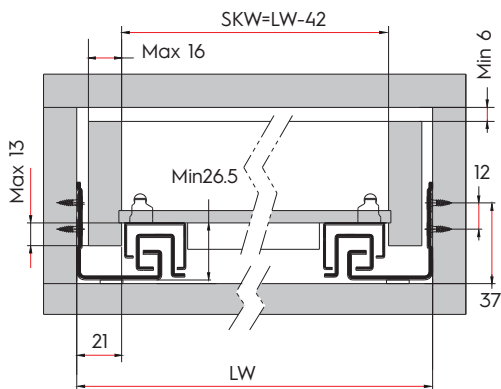



Cutting dimension of rod for push-open Synchronization(mm)

Max 16mm drawer side-cutting dimension of rod for push-open Synchronization

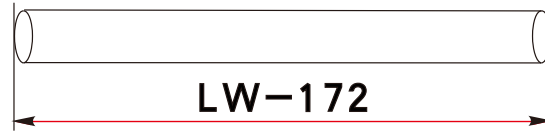

Back Assembly

2D Locking Clip Assembly

3D Locking Clip Assembly

Drawer Back Preparation (mm)

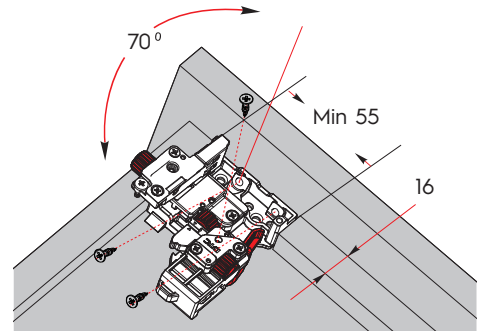
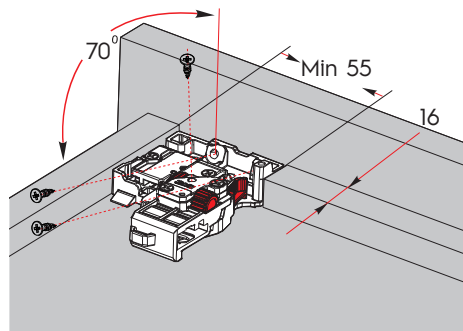
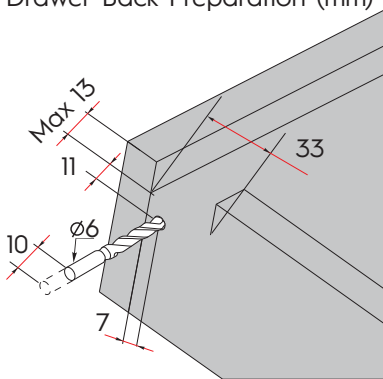

Drawer Assembly

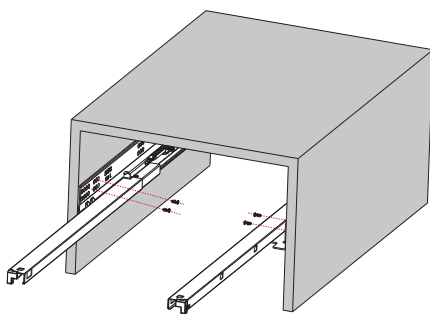

Fix the slides onto the cabinet.

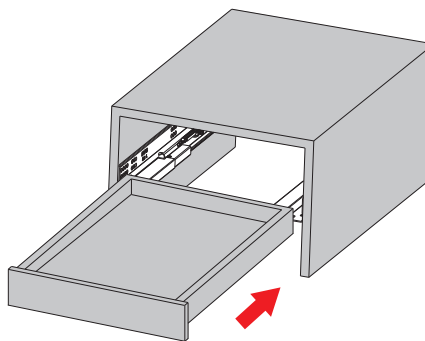

Lay the drawer bottom onto the slide then push the drawer into the cabinet

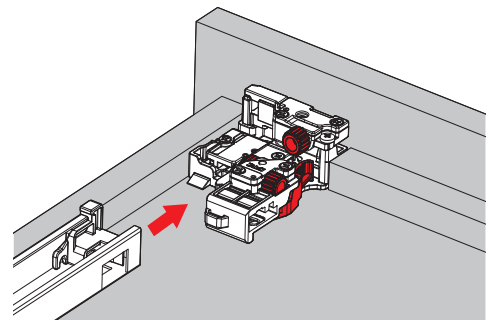

Slides should click into place, if not will have to be adjusted from the bottom.



Synchronization push-open rod assembly

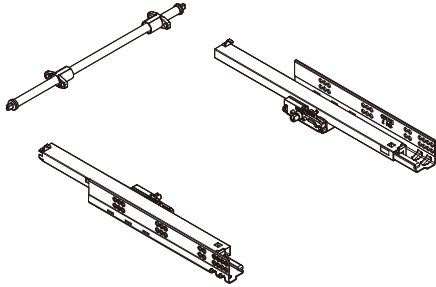

Cut the rod

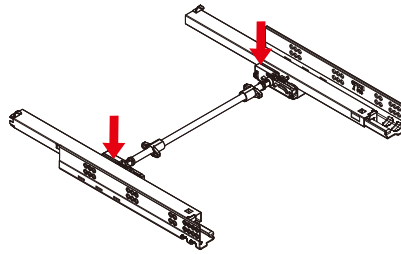

Snap the rod into push-open device on the slide

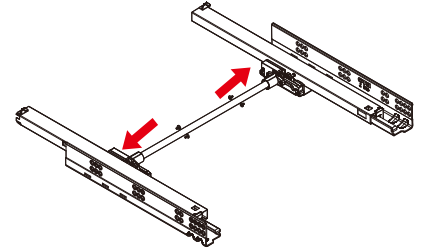

Screw on and finish

6-Way Drawer Assembly Adjustment

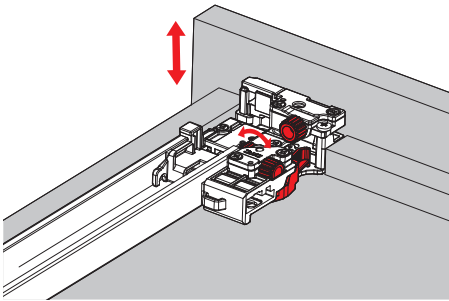

Up & Down Adjustment

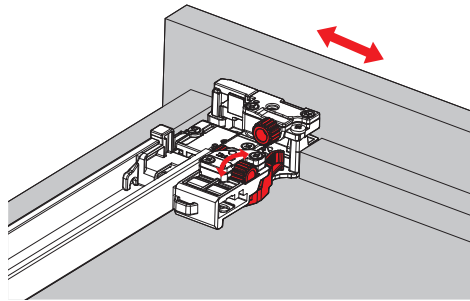

Side to Side Adjustment

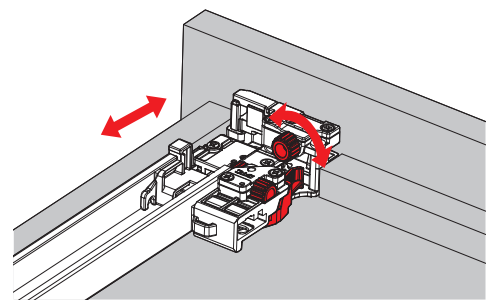

Depth Adjustment

4-Way Drawer Assembly Adjustment

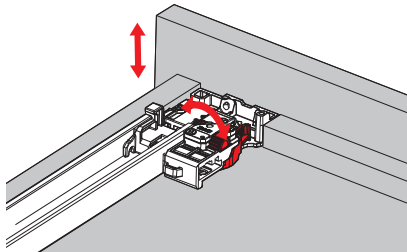

Up & Down Adjustment

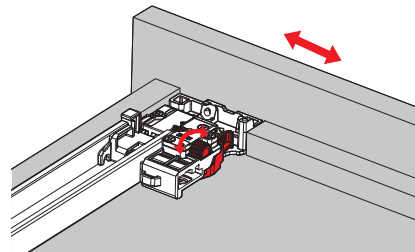

Side to Side Adjustment

Drawer Removal

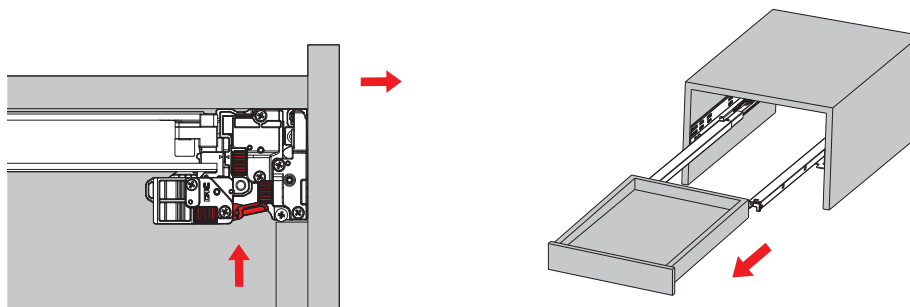

For Removal, Hold the Handle and pull out the drawer