

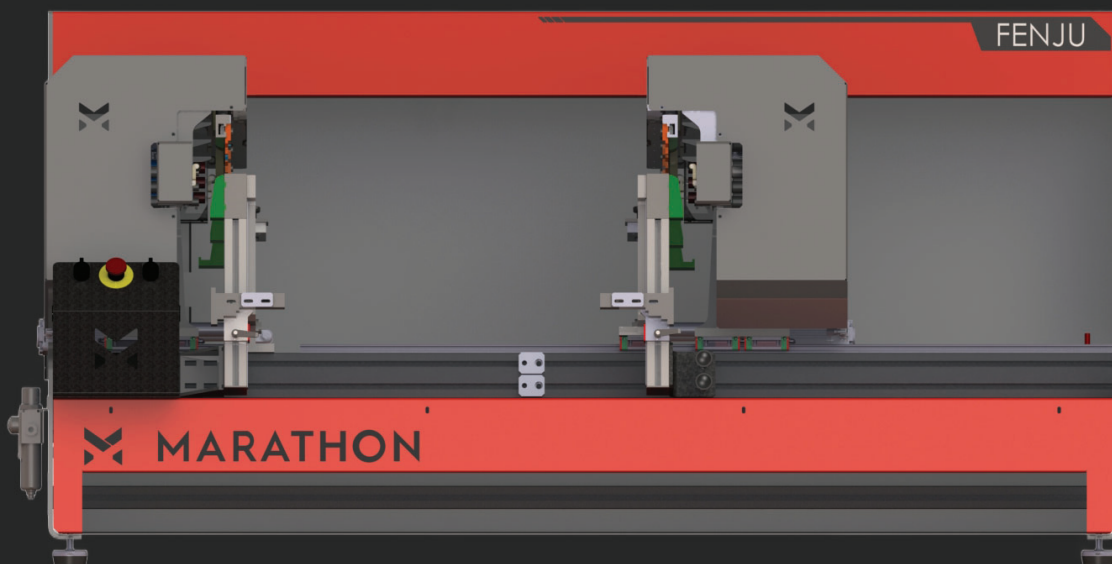

MARATHON

H A R D W A R E

ECM-A DRAWER MACHINE



OPERATING MANUAL

Table of Contents

1. GENERAL CHARACTERISTICS OF THE SUPPLY

- 1.1 General Information
- 1.2 Machine Identification
- 1.3 Important Safety Instructions

2. SAFETY INSTRUCTIONS

- 2.1. Regulations
- 2.2. General Safety Instructions
- 2.3. Representation of Safety Symbols
- 2.4. Obligations of the User
- 2.5. Danger Areas
- 2.6. Operators and Technical Personnel
 - 2.6.1. Operators
 - 2.6.2. Technical Personnel
- 2.7. Warning Symbol

3. INTENDED USE

- 3.1. Tasks
- 3.2. Limits

4. TECHNICAL DATA

- 4.1. Taking Delivery of the Machine

5. DISPOSING OF EQUIPMENT

6. TRANSPORT, PACKAGING AND STORAGE

- 6.1. Transport to Customer's Location
- 6.2. Transport inside Customer's Location
- 6.3. Disposing of Packaging
- 6.4. Storage

7. INSTALLATION

- 7.1. Pneumatic Installation
- 7.2. Recommendations
- 7.3. Machine Control Panel
- 7.4. Assembly Steps
 - 7.4.1. Distance Adjustment
 - 7.4.1.1. Drawer Length Adjustment
 - 7.4.1.2. Drawer Height Adjustment
 - 7.4.1.3. Drawer Bottom Adjustment
 - 7.4.1.4. Punch Adjustment
- 7.5. Emergency Stop and Restart of the Machine
- 7.6. Model INFINITY Adjustment
- 7.7. Model M-SERIES Adjustment
- 7.8. Stroke End Position Adjustment

8. RECOMMENDATIONS

9. SAFETY SYSTEM

- 9.1. Time Delay Valve
- 9.2. Stopper

10. MAINTENANCE

- 10.1. Grease the Skids
- 10.2. Working Speed Adjustment
- 10.3. Head Retreat Adjustment

11. INSPECTION

12. APPENDIX



EU Declaration of Conformity

Manufacturer



We herewith declare that the product defined below complies with the appropriate basic requirements regarding safety and health and relevant provisions of the relevant EU Directives by design, type and the versions which are brought into circulation by us.

Description of the machine:

Product	NAILING MACHINE
Model	AUTOMATIC
Serial Number	001
Manufacture Date	JUL/22
Brand	FENJU
Type	PNEUMATIC

This product meets the requirements of the 2006/42/CE Directive, 17th May 2006.

This machine complies with all the essential health and safety requirements described in this manual. It is not included in Appendix IV. The above equipment was designed and manufactured in accordance with:

UNE-EN ISO 12100-1:2004, EN ISO 13857:2008, EN 60204-1

Operating the machine is hereby strictly forbidden before confirming all necessary steps have been taken into consideration and confirmed the fully installation/product conforms the regulation.

Technical management	FENJU S.L.
Place, date	

1. GENERAL CHARACTERISTICS OF THE SUPPLY

1.1. General Information

The descriptions and illustrations contained in this manual are not binding. FENJU S.L. reserves the right to make any technical modifications it deems necessary at any time to improve the performance of the machine, or due to industrial requirements.

IT IS STRONGLY RECOMMENDED NOT TO MAKE ANY MODIFICATION TO THE MACHINE WITHOUT PRIOR WRITTEN AUTHORIZATION FROM THE MANUFACTURER, NEITHER ELECTRICAL NOR MECHANICAL AND OF ANY KIND.

FENJU S.L. ACCEPTS NO LIABILITY FOR INJURY, PROPERTY DAMAGE, LOSS OR EXPENSE ARISING FROM INAPPROPRIATE USE.

Keep the operating manual in a safe place for future use. As it provides important information on safe and efficient handling of the machine it is highly recommended to be kept with the other elements of the machine – the hydraulic and electrical diagram and spare parts manual, where it will be easily found.

Knowledge of the basic safety information and safety regulations is a requirement for safe handling and fault-free machine operation. The operator must understand the information contained in this document as it describes all elements and functionalities of the machine.

This operating manual contains essential information for correct operation and for the operator to work safely.

SYMBOLS:

- Please pay attention when a text is marked in bold in a red box as it is especially relevant
- Symbol  indicates safety instructions and recommendations to keep plank loader working correctly

Read carefully and understand the information in the operating manual before starting or lubricating the machine.

Knowledge of the basic safety information and safety regulations is a requirement for safe handling and fault-free machine operation. Manufacturer accepts no liability for injury, property damage, loss or expense arising from inappropriate use.

1.2. Machine Identification

A riveted metal plate can be found at one side providing the following information:

- A. Company name
- B. Operating areas
- C. Company address



For further information and technical support please do not hesitate to contact us.

1.3. Important Safety Instructions

SAFETY INSTRUCTIONS THAT MUST STRICTLY BE FOLLOWED BY ANY OPERATOR:

- Before operating with the machine, all safety and warning symbols must be correctly placed.
- Shut the machine completely off before making adjustments or replacing any parts to prevent accidental power on.
- Regularly check oil distribution tank level.. It is important in order to keep the hydraulic components perfectly lubricated.
- Periodically remove from the machine, any pieces that may remain when cutting.
- Keep the working area clean.
- Strictly follow maintenance schedule.
- Turn off the machine before cleaning.
- In case of fire, use a powder extinguisher.
- Fixed guards shall not be removed under any circumstances while the machine is in use.
- Keep the machine in perfect condition and replace broken or damaged parts.

- Clean the machine regularly.
- Do not leave the machine unattended when it is in operation.
- Do not allow unauthorized persons to approach the machine during operation.
- If the user discovers that a function is not working properly then they should report this fault to the personnel assigned to maintenance tasks.
- Before starting the machine, check that there are no foreign objects in the machine.

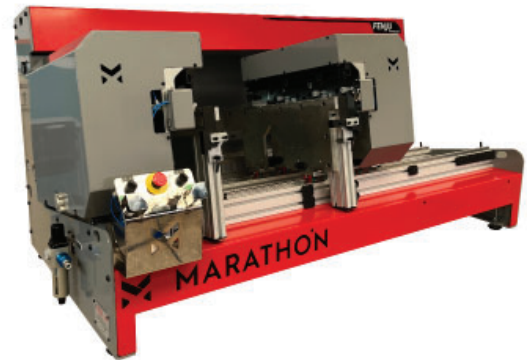
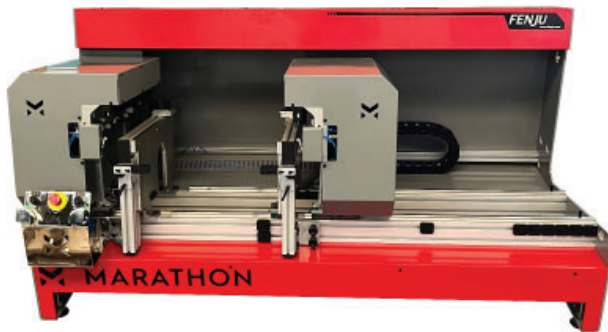

2. SAFETY INSTRUCTIONS

2.1. Regulations

The model AUTOMÁTICA machine has been built in accordance with the following European standards:

EC machine standard (89/392/EEC, 91/3678/EEC, 93/44/EEC and 93/68/EEC).

As well, all the safety information in this operating manual complies with the general, national regulations pertaining to accident prevention. The locally applicable regulations of the association for the prevention of and insurance against accidents at work must always be observed.

2.2. General Safety Instructions

- Please ensure that all the machine operators have read this operating manual before they put the machine into operation. Only those people who have been trained and instructed by the seller may work with/on the machine.
- People with specialist technical training shall be considered as a specialist. Only instructed persons shall work with/on the machine.
- It is essential that all operators are properly trained in the use, adjustment and operation of the machine. This shall include the correct use and adjustment

of any guards and necessary personal protective equipment as protection for eyes and ears.

- Faulty or disassembled safety and protection equipment can lead to dangerous situations.
- Check all the safety and protection instructions.
- The machine may only be used for the purpose for which it is intended. All protective devices must be installed, and all relevant safety regulations must also be observed.
- Maintenance work may only be carried out by trained and professionally qualified personnel. National safety regulations must be considered.
- When carrying out repair and maintenance work on pneumatic equipment, the machine must be disconnected from the pneumatic power supply. Exceptions are only accepted in the case of adjustments or checks carried out by specialist personnel.
- You may make no changes, expansions or modifications to the machine.
- Use only genuine FENJU S.L. spare parts and accessories so that the operating permit retains its validity in accordance with national and international regulations. FENJU S.L. accepts no liability for damage arising from the use of unapproved spare parts or auxiliary materials. Use of unauthorized spare parts may have a negative effect on the functioning of the machine.

2.3. Representation of Safety Symbols



Indicates an immediate high risk and requires special attention.



Injury risk for operator or technical person!

Indicates an immediate high risk, which will result in death or extremely serious physical injury (loss of body parts or long term damage) if not avoided.

2.4. Obligations of the User

- This operating manual is a component part of the machine and must always be easily accessible for the user and maintenance personnel.
- Qualified personnel and those who operate the machine must be instructed in protective equipment and measures.
- Only operate the machine if all the safety and protection equipment is fully functional.
- Never open or remove guard devices.
- Only those people who have been instructed and authorized may work with/on the machine.

- The operator must ensure that only persons with the appropriate technical qualifications work on the machine.
- Ensure proper use of the machine, tools and speed are adequate as described in this manual.

2.5. Danger Areas



DANGER

Be particularly careful when working on these selected areas of the machine:

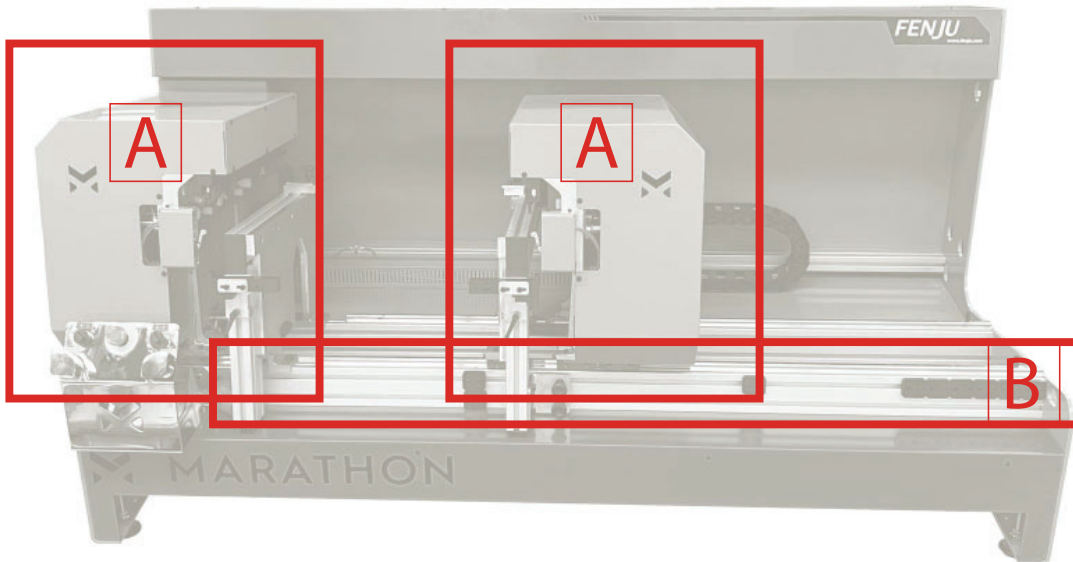

“A” area. Risk of hands being trapped in the drawer assembly area. Do not insert a hand or any other part of the body during the machine’s working cycle. Be particularly careful not to bump against the machine parts.

“B” area. Stop system. During adjustment tasks ensure not to insert a hand between stop system and rocker arms. Be careful not to reach between the fixed and moving parts of the machine.

**BE PARTICULARLY CAREFUL WHEN OPENING AIR VALVE.
SOME PARTS MAY HAVE BEEN MOVED TO STARTING POINT.**

2.6. Operators and Technical Personnel

2.6.1. Operators

The operator shall carry out maintenance, repair and cleaning of the machine. Ensure sliding carriages speed is properly adjusted.

Obligations of the operator:

- Be aware of the basic workplace safety information and accident prevention regulations.
- Eliminate any faults that could impair safety immediately.
- Comply with the general, national regulations pertaining to accident prevention.
- Ensure only trained personnel get close to the danger area.
- Communicate any external adjustment (internally, to their superior or to the user who possess the appropriate technical knowledge) which may affect safety and security.
- If the user discovers that a function is not working properly, then they must communicate this fault immediately (internally, to their superior or to the user who possess the appropriate technical knowledge).
- Any use that goes beyond marked limits is not regarded as the intended use.

2.6.2. Technical Personnel

- The technical personnel must have professional training in electricity, electronics, mechanics and pneumatics.
- Obligations of the technical specialist:
 - Be aware of all safety information and accident prevention regulations contained in this manual.
 - When carrying out repair and maintenance work on pneumatic equipment, the machine must be disconnected from the pneumatic power supply.
 - Before starting any intervention on the machine, press the emergency stop button and do not release it until the intervention on the machine is finished.
 - Replace safety guards after maintenance and repair work.
 - National safety regulations must be considered.

Any user shall require written approval in order to carry out maintenance and repair work. FENJU S.L. shall not be responsible for any non-authorized personnel, including suppliers, resellers or freelancers.

2.7. Warning Symbol



Danger area!

Indicates an immediate high risk and requires special attention!



Indicates risk for operator and technical personnel.

This hazard can cause extremely serious injuries anywhere on the body, or even death.

3. INTENDED USE

3.1. Tasks

Model AUTOMÁTICA has been designed to square and crimp several items in order to form drawers for all types of furniture. These elements are standard and shall be provided by hardware suppliers.

Each machine has been particularly set up and adjusted to only one drawer specification. Only valid for wooden back and floor assembly.



AUTOMÁTICA machine is designed only for professional use. This equipment requires fixed installation.

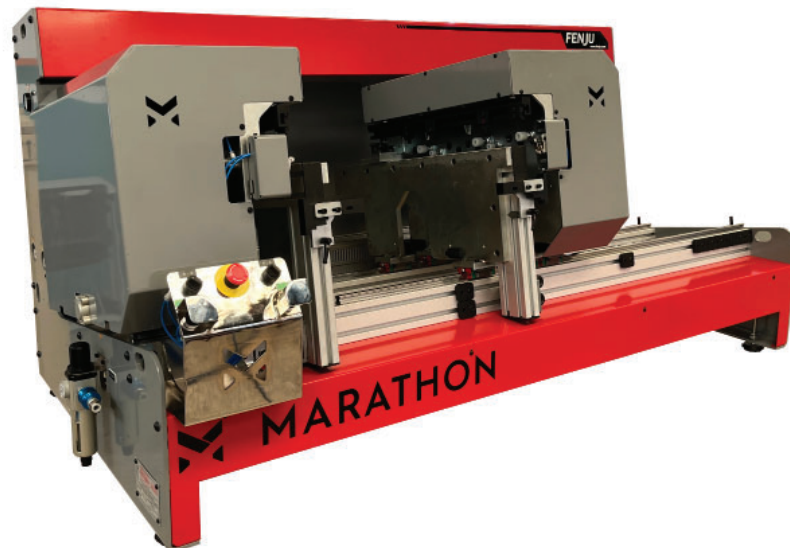

Any use that goes beyond indicated limits is not regarded as the intended use. Consequence of nonobservance may cause serious injuries.



WARNING: Any mechanical, electrical, electronic or pneumatic modification to extend defined limits or to give the machine an application other than that which has been originally designed by manufacturer, is not allowed.

3.2. Limits



AUTOMÁTICA model: Do not exceed the following limits:

- Minimum drawer length: 250 mm
- Maximum drawer length: 1200 mm
- Minimum drawer slide length: 270 mm
- Maximum drawer slide length: 600mm
- Minimum drawer back depth: 84 mm
- Maximum drawer back depth: 248 mm
- Drawer material: Wood

Note: measures may be customized under customer's request.



Any use which goes beyond these limits is not regarded as the intended use. Intended use also includes compliance with instructions specified by the manufacturer concerning operation, servicing and maintenance as well as the exclusive use of manufacturer.

The following tasks may not be carried out using the AUTOMÁTICA machine:

- Assembly of elements for which the machine has not been designed for. Any modification must always be carried out by a FENJU S.L. technician.
- Assembly of elements on back or floors that are not entirely made of wood.

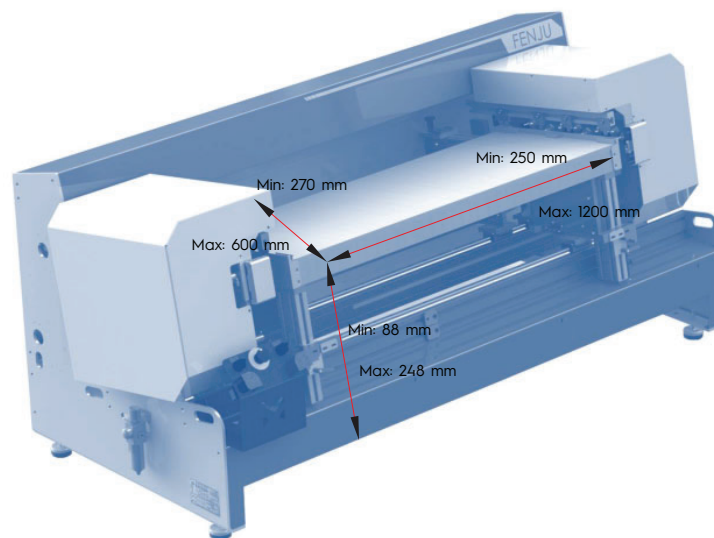

4. TECHNICAL DATA

Air pressure: 6 kg/cm

Air consumption per cycle: 10 L

Approximate weight: 297 kg

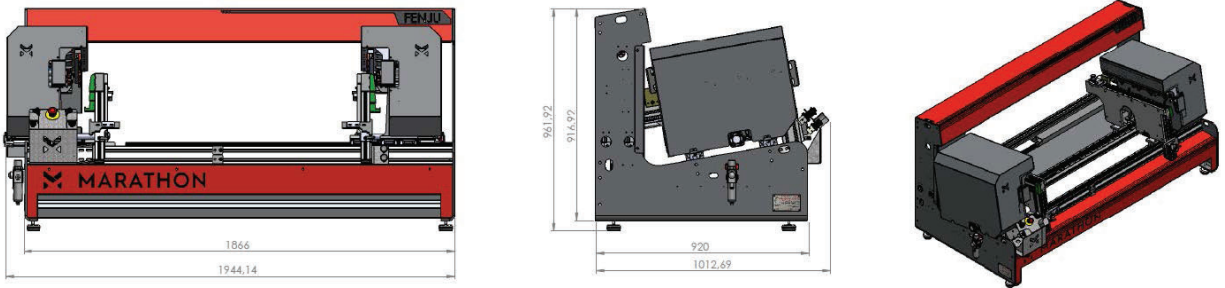

Note: Measures do not include bench / workbench.
Standard machine shall be assembled on a workbench.

4.1. Taking Delivery of the Machine



The machine is supplied in wooden packaging. Forklifts and/or pallet trucks can be used to manipulate packaging.

Weight of the machine in its packaging: 485 kg

Dimensions:

Length: 2130 mm

Height: 1120 mm

Depth: 1180 mm

5. DISPOSING OF EQUIPMENT

The disposal of the machine and the used parts is the customer's responsibility and must take place in accordance with local regulations.

Materials in the AUTOMÁTICA machine are: steel, aluminum, brass and various plastics.

This machine is to be placed for disposal or recycling in the waste separation systems provided for this purpose. Observe the local regulations regarding disposal.



Ensure that lubricant-soaked parts are disposed of separately and in accordance with the environmental protection regulations local to where the machine is installed.

6. TRANSPORT, PACKAGING AND STORAGE

6.1. Transport to Customer's Location

The machine is delivered. The machines destined for export are properly packed. The delivery conditions are EXW (Ex Works). FENJU, S.L. accepts no liability for damage arising from transport from our facilities to customer's facilities even when the shipping has been arranged by FENJU, S.L.

The guarantee does not cover cases where damage occurs during shipping, even when the shipping has been arranged by FENJU, S.L.

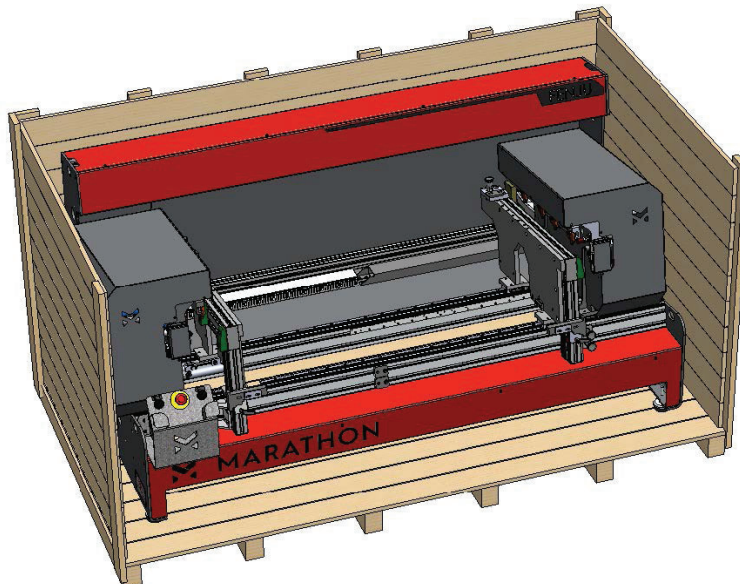

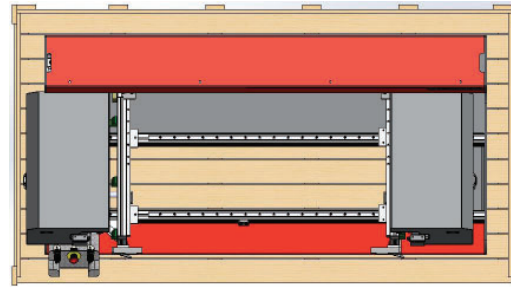
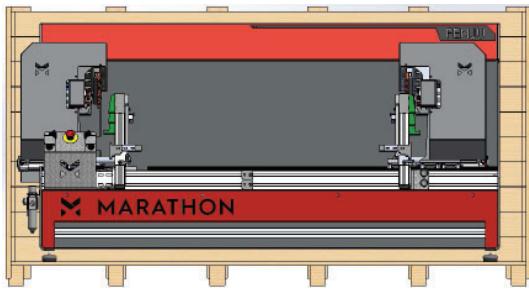

6.2. Transport inside Customer's Location

Manufacturer accepts no liability for damage or any kind arising from transport at customer's location. Ensure parcel is set and transported in a horizontal position and safety regulations are observed.



Machine shall remain in its original packaging until arriving at its final destination. Use mechanical means such as forklifts or pallet trucks.

Please consider not only weight (machine + packaging) but also dimensions.



Do not use cranes or any other element which suspend the machine in the air by chains, cables, ropes, straps, etc.

Please observe the danger of crushing, catching or lumbar injuries during transportation in order to avoid risks.

Besides the safety information in this operating manual, the national general workplace safety and accident prevention regulations are binding.

6.3. Disposing of Packaging

The packaging is made of wood, paper and cardboard. Customer is responsible for proper disposal.

6.4. Storage

Should the machine not be used for a period longer than one month, please keep it protected from humidity and dirt.

Corrosion may affect individual parts and therefore should be protected. Pay special attention to sliding surfaces by applying oil, for example. Electronic systems with data backup batteries may need to be set up after one month. This operation shall be done by manufacturer FENJU S.L.

7. INSTALLATION



Only instructed persons authorized by the supplier shall install and start-up the machine. Invoicing companies will be considered the supplier for these effects.



Depending on where the machine will be used, installation must also observe national regulations.



Please consider weight of the machine while unpacking. There are lateral openings on each side to lift it. Fix lifting elements only to these specific lashing points and no others.

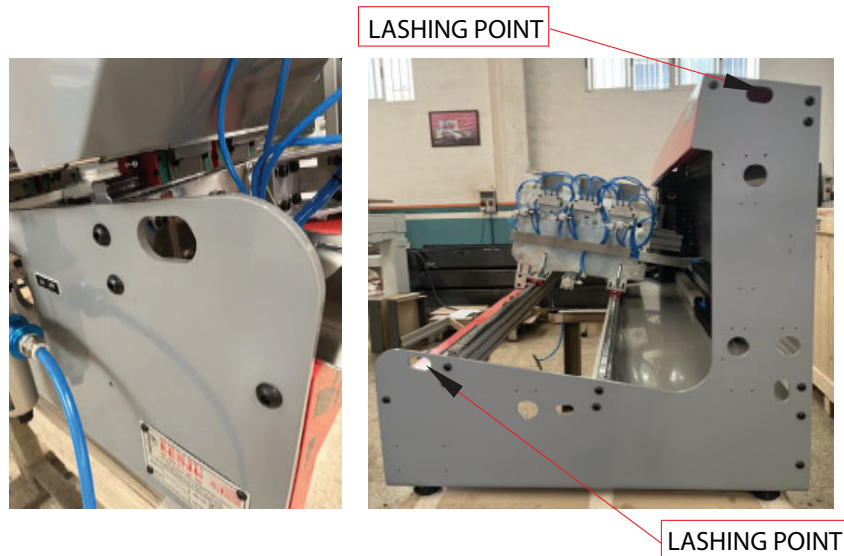

IT IS RECOMMENDED TO REMOVE THE LEFT GUARD WHEN HANDLING THE MACHING TO AVOID CHASSIS DAMAGE.



DANGER

Do not spend time in the danger area underneath raised machine parts. Secure the raised parts against descending unintentionally.

For transportation purposes, the machine is protected by appropriate packaging. Workbench shall be located at the back, if included. To avoid damage, do not remove workbench plastic fastener before unboxing.

The machine is supplied fully assembled and ready for its installation at the final site. Install on a workbench using the 4 holes located on the bottom of the machine.

Ensure fastening to workbench is stable and solid. Workbench will be provided by user.

As the workbench must support not only the machine but also other pieces, make sure it is an appropriate and robust structure and larger than the machine. Use the indicated holes at the bottom to fix the machine to the workbench. Workbench must have a slip-resistant surface and be easy to clean.



In case of severe vibration or movements, replace workbench for a more robust one.

Install the machine in the horizontal position on the workbench. Do not force the machine into alternate positions while working. Workbench height shall be approximately 600mm to 800mm. Locate final position of central area between 960mm and 1225mm.

This machine is designed to be use by one operator in “standing” position facing towards the front of the machine.

Workbench is available as special accessory for installation (not included).

Place the machine on a flat and stable surface, keeping in mind workpiece dimensions. When handling workpieces, there must always be a free space double that of the workpiece plus 1 additional metre around the machine. Leave at least 1.5m of free space in front of the machine. The height of the machine shall be adapted to the operator so it is the most comfortable while working on the machine. Inadequate posture can lead to health problems. If necessary, an adjustable platform may be installed in the case that multiple operators have access to the machine.



It is the customer’s responsibility to ensure a correct amount of space, considering both machine design and operation. The manufacturer accepts no liability in this regard. Both working area and workbench must observe national regulations of the country where the machine is installed. If there is any conflict between this operating manual and national regulation, national regulation of the country where the machine is installed shall prevail. For example, EN ISO 14738 for space planning and workstation design in Spain and other European countries.

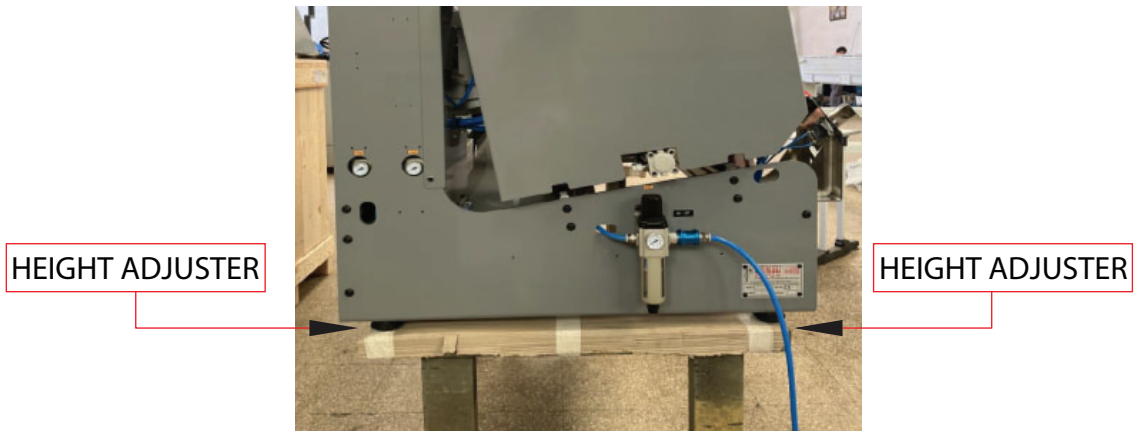

7.1. Pneumatic Installation



Only an authorized operator is allowed to proceed with pneumatic installation. National regulations of the country where the machine is installed must be observed.

Use 8 mm inner diameter flexible rubber which supports at least 16 kg pressure to plug metal connector located at the right side of the machine, above general pneumatic shut-off valve. Do not use quick coupling connections.

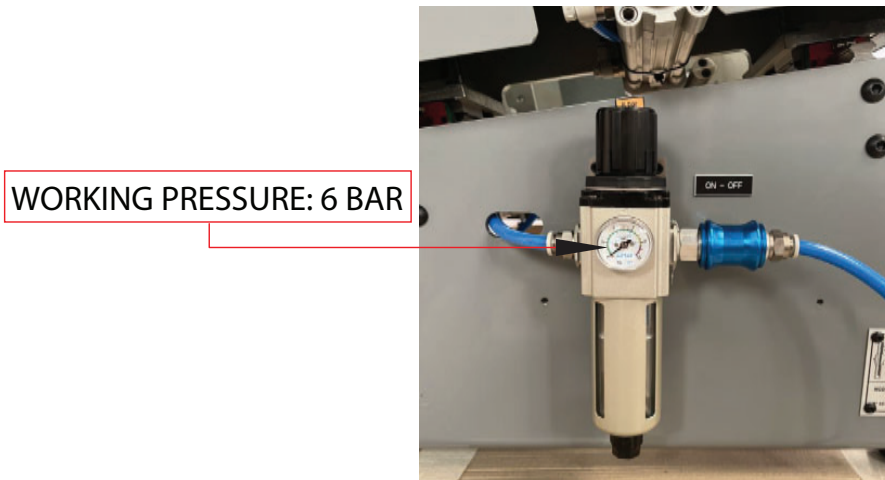

If the machine does not seem to be working properly, make sure the valve is located on the ON position.

Maximum pressure supported by pneumatic installed components is 10 kg. Install pressure reducing valve if necessary (not included) which supports at least the existing pressure in the pneumatic net.

Quick coupling connections or similar systems should not be used to connect the machine to the pneumatic net. Valve fixed connections should be used in order to isolate the machine from the general factory network.

A working pressure of 6-7 kg/cm² is applied. Lower pressure can lead to crimp issues under certain circumstances (for example, wood covered with hard surfaces). Ensure air flow is correct. Pressure drop should not exceed 0.25 kg/cm² otherwise the machine shall not work properly.

7.2. Recommendations



A qualified and professional operator with appropriate technical knowledge about the use of machines shall be present during the assembly phase.

Only instructed persons authorized by supplier shall install and start-up the machine. The invoicing company will be considered supplier for these effects.

The seller shall never be responsible for the use nor the knowledge that the operator acquires on the machine.

It is recommended that only one person works on the machine – the same person who was present during the assembly phase. Workspace should also be adjusted to this person.

Should more operators work on the machine, ensure all of them have the necessary knowledge to work safely. Workspace should also be adapted to new operator(s).

Do not connect the machine to any air supply network exceeding maximum recommended level.



Personal protective equipment, such as protective glasses, is mandatory. General workplace safety and accident prevention regulations are binding.



DANGER

Never open or remove guard devices.



Risk of fingers or hands being crushed by accessible moving machine parts. Before any adjustment, shut off the pneumatic connection. Do not introduce any part of the body in the working area.

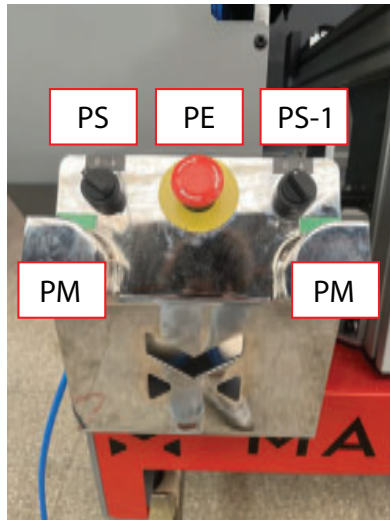

7.3. Machine Control Panel

- a) PM. Cycle start buttons. Both shall remain pressed during the whole cycle. They shall be pressed simultaneously with a maximum difference of 0.5 sec. Release at least one button to interrupt working cycle. These buttons are protected to avoid accidental presses.
- b) PE. Emergency stop button. Press to shut down equipment in the case of an emergency.
- c) PS: Clamping selector. Activate for side drawer clamping.
- d) PS-1: Clamping selector model INFINITY. Activate for side drawer clamping. After activation, PS control may be used to better adjust lateral hold, if necessary.

7.4. Assembly Steps

Drawer assembly process consists of 3 steps:

- Distance adjustment
- Placement of all elements which shall form a drawer on the machine
- Automatic assembly of the drawer

7.4.1. Distance Adjustment

7.4.1.1. Drawer Length Adjustment

There are 2 horizontal elements, a fixed one located on the left side (5) and a moving one on the right side of the machine (5).

Mobile part (5) is operated manually.

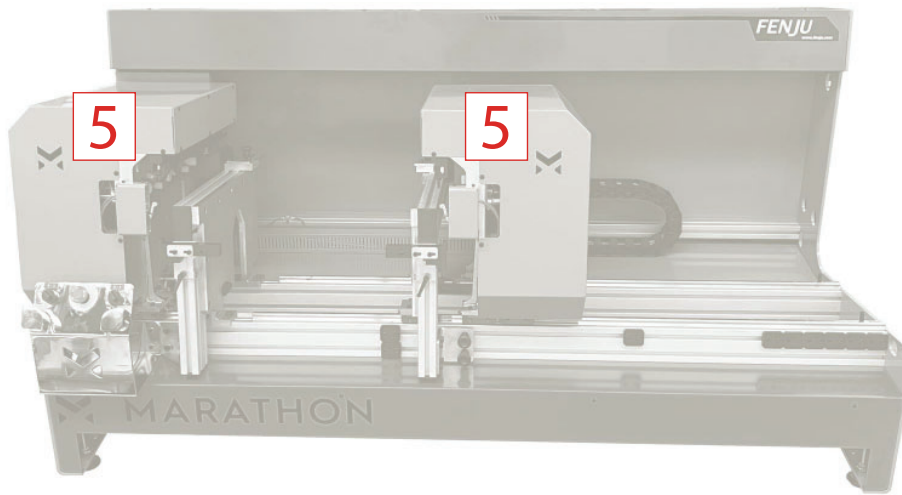

Risk of fingers or hands being crushed by accessible moving machine parts. Never introduce hand between fixed and moving parts.

Place moving element of the machine to a distance that allows introducing back and bottom sides of the drawer, activate control (6) and insert it on the slot stop (2) that corresponds to this measure.

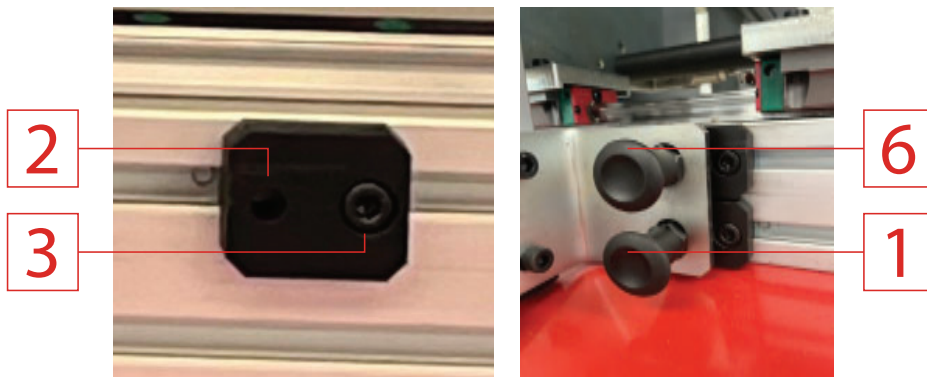

Important! Do not operate the machine if lever is not placed at a slot stop. Slot stops must be firmly tightened to the bar by a screw (3).

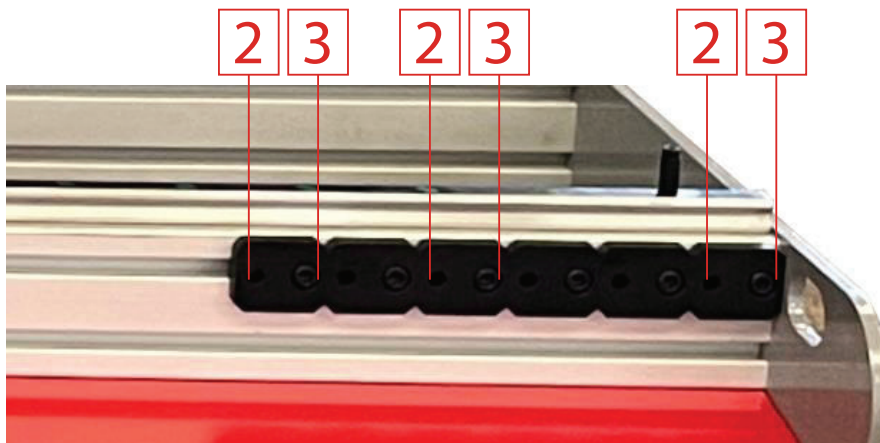

Upper locks have been designed to be fixed to the standard drawer sizes in order to facilitate operator's work and speed up production.

Lower locks have been designed to be fixed to less common positions or any other specific distance.

Once moving parts have been properly adjusted and after lever has been inserted to the slot stop, lock it by pressing button 1.

This function permits a better clamping by locking the two positions. Lower locking device also has this function.

7.4.1.2. Drawer Height Adjustment

Adjust bottom of the drawer by placing the horizontal moving parts (9). Notches at the stop bar (8) mark different distances. Lose locking screw (10) to slide mounting elements (9) on horizontal profiles (5). Pull up the blocking knob (11) and move it to the selected position. Tighten the locking screw (10). Repeat on the other side.

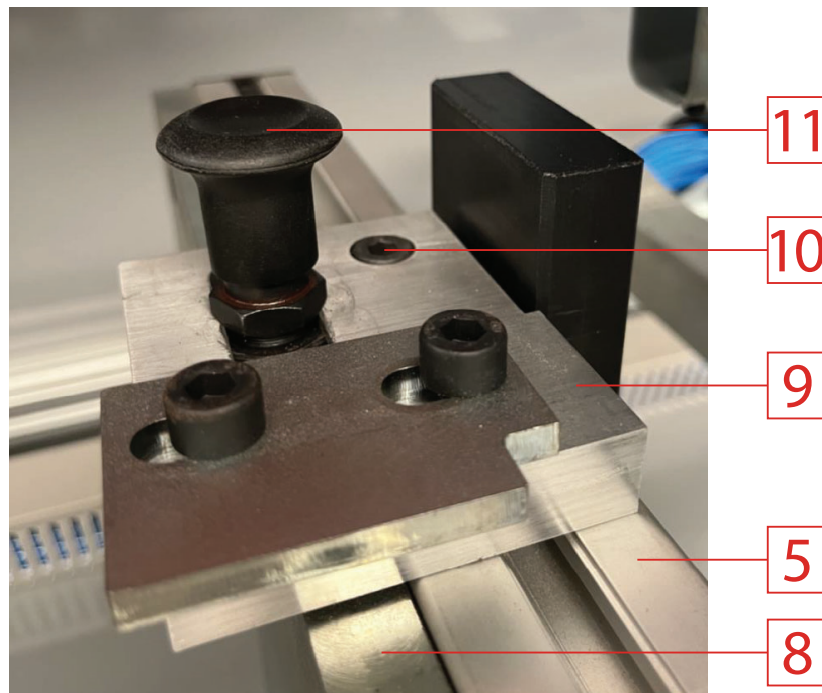

Risk of fingers or hands being crushed by accessible moving machine parts. Never introduce hand between fix and moving parts.

**IT IS STRICTLY FORBIDDEN TO ADJUST THE MACHINE WITH PRESSURE.
THE MACHINE MUST ALWAYS BE ADJUSTED WITHOUT BEING
CONNECTED TO THE AIR INTAKE.**

7.4.1.3. Drawer Bottom Adjustment

Assemble drawer hardware and then find two stops (19) which allow positioning the back of the drawer. Please note the arrow on a metric ruler (20) to better select the measure. By loosening the screws (21) stop can be moved to adapt to different side sizes.

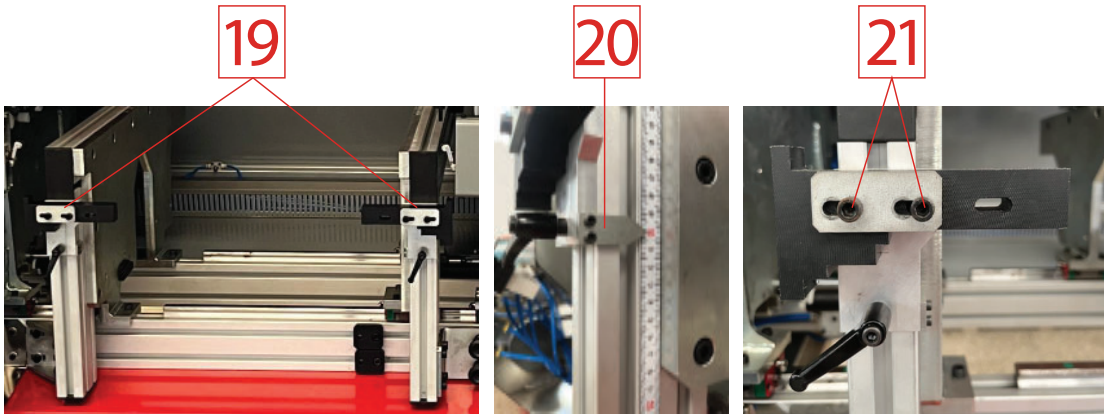

Once bottom of the drawer is successfully adjusted, block position with control (21) and repeat with the opposite stop.

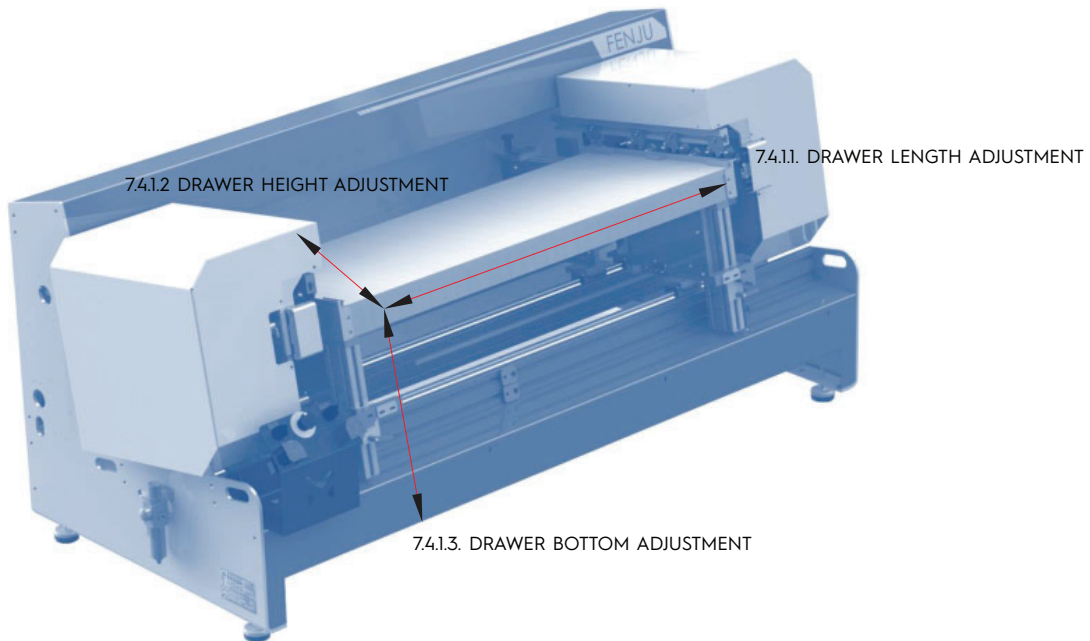

7.4.1.4. Punch Adjustment

The punches are independent and can be slid along a mechanized profile. Thanks to this, the operator can adjust punches in an easy and precise way. Furthermore, it opens the possibility to work with different kind of drawers and clipping positions.

Design offers a mechanized profile screwed to clamping pressure cylinders, 4 moving punches that slide along the profile and clamping nuts to fix the punches once they have been correctly located, to prevent them from moving during clipping.

Thanks to a metric ruler, precise positioning of the punches is possible.

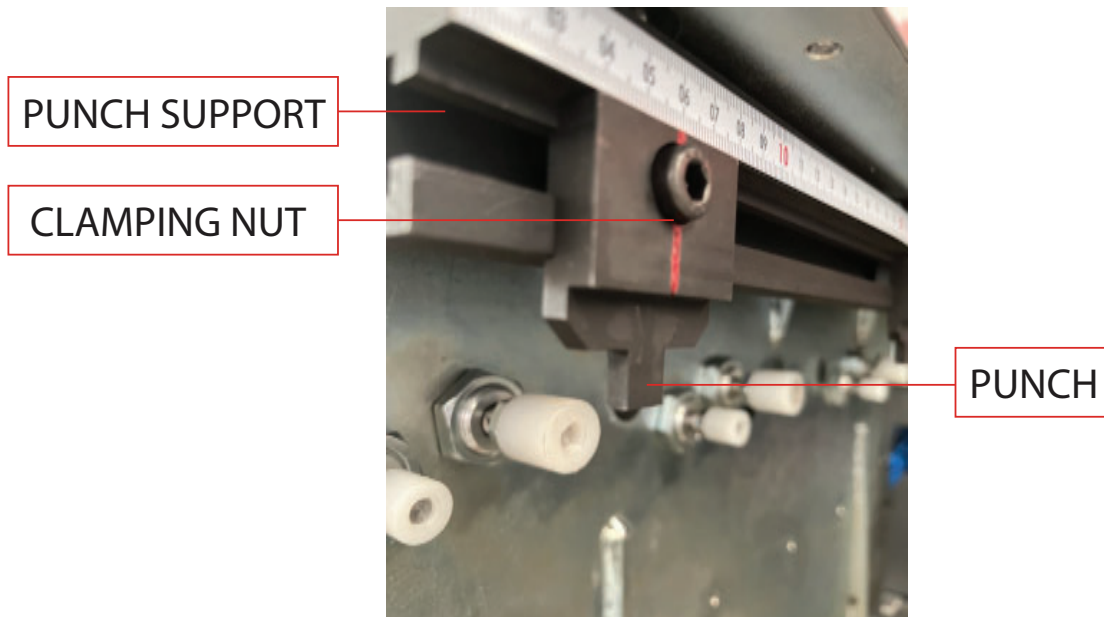

Place bottom on the machine, side parts on the right and left sides and back of the drawer on the front side of the machine, leaned on the support (19).

Once all pieces have been placed on the machine, press button PS. Lateral pneumatic cylinders shall be activated and hold drawer sides against bottom. Press the two push buttons (PM) simultaneously by a maximum difference of 0.5 seconds. If by any chance the bimanual push buttons are pressed alternatively, system will not work as it is designed to be pressed at the same time (two-hand regulation). Keep the buttons pressed during the whole working cycle of the machine.

The machine clamps, assembles and crimps the drawer. Once the whole

process of the machine is finished, release the buttons so that the punches return to their resting state. Fully assembled drawer shall be released.

Two-hand regulation has been observed. Keep the buttons pressed during the whole working cycle of the machine; the machine clamps, assembles and crimps the drawer. Once the whole process of the machine is finished, release the buttons so that the punches return to their resting state. Fully assembled drawer shall be released. Verify clipping is correct and unblock the selector blocking the drawer to extract it from the machine.



Do not put your hand between any moving parts of the machine. Do not hold the back of the drawer with your hand. Release push buttons (PM) if necessary and press emergency stop button (PE).

In order to guarantee a proper assembly of the drawer, it is necessary to assemble the whole set of parts, i.e. back, bottom and 2 sides.

7.5. Emergency Stop and Restart of the Machine

“Emergency” button (PE) can be pressed in case there is any problem during a working cycle. The machine will stop and return to its initial position.

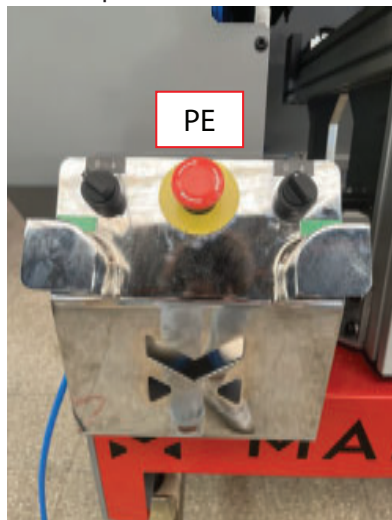

Once it has been pressed, button should remain locked. To release it and restart the machine's working cycle, unlock it by turning the knob clockwise a quarter turn.

Do not use the machine if the emergency button (PE) do not remain locked. Have it replaced by a qualified technician. Do not work under these conditions, it involves a serious risk.



Emergency stop should not be used such as regular stop. Emergency stop can only be used in case of dangerous situations, certain adjustments or when isolating the machine from the pneumatic net of the facility.

In order to make a regular stop just release one of the push buttons pressed at the beginning of the cycle and machine work cycle will stop.

7.6. Model Infinity Adjustment

INFINITY model can easily be adjusted by specific molds that fit perfectly.

These molds are very easy to place. Just remove horizontal profile cover and insert the nuts.

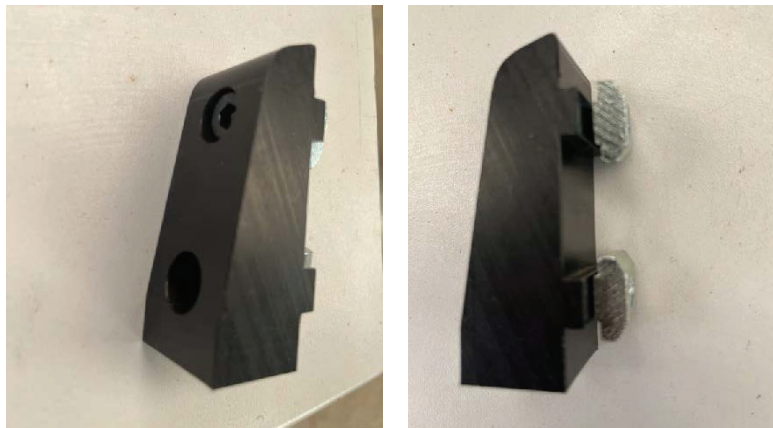

Turn the trigger once they are placed to prevent them from moving and clipping wrong area.

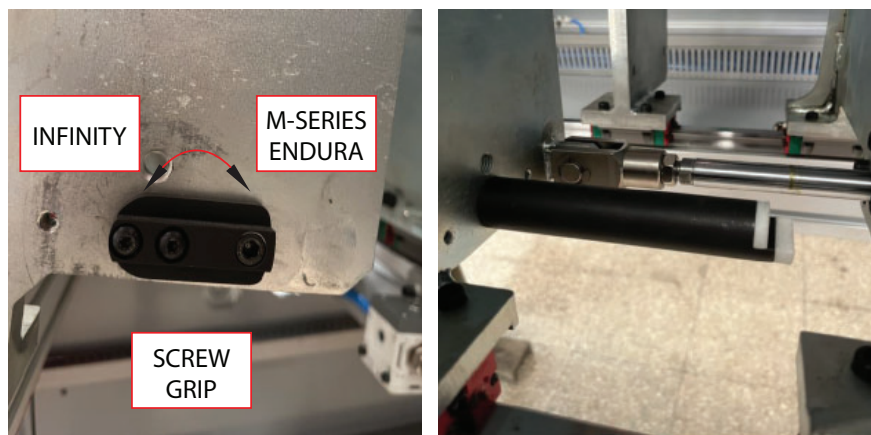

Adjust it just by turning the trigger to one side for M-SERIE and ENDURA models. For model INIFINITY turn it to the opposite side.

7.7. Model M-Series Adjustment

Model M-SERIE contains a specially desinged punch. It is only available for this model and not compatible with other models. Clipping is adjusted with pressure as bending depth can be adjusted by using M-SERIES flanges.

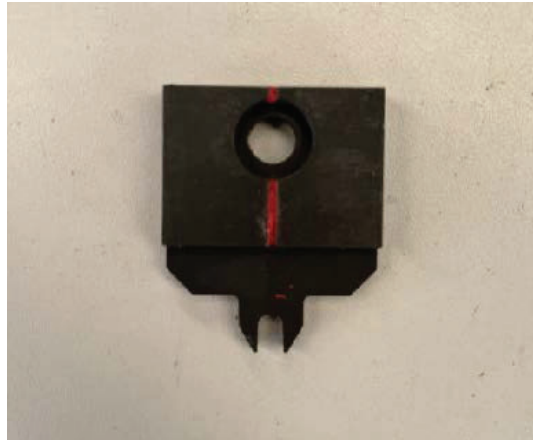

7.8. Stroke End Position Adjustment

Set front limit switches according to drawer measures. Once correctly located, put the heads in their rest position and connect the machine.

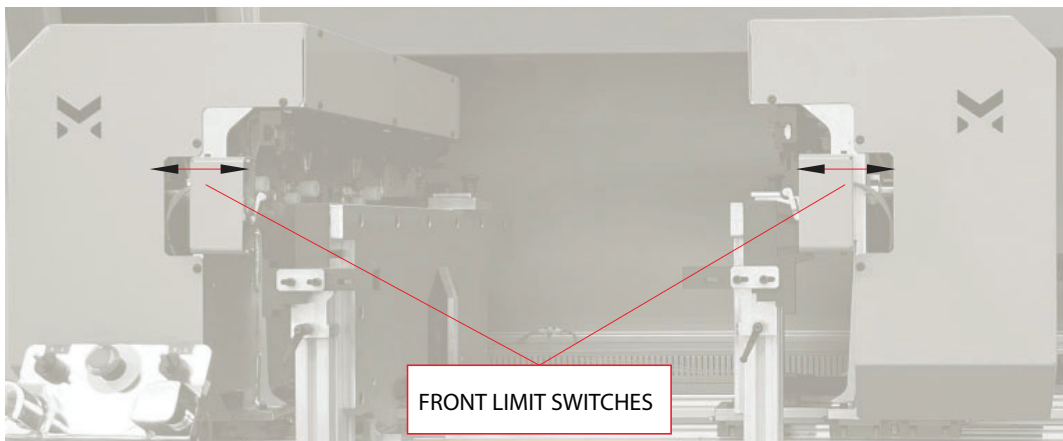

8. RECOMMENDATIONS

The machine shall always be used by the same operator.



Do not put your hands under any of the moving parts. Do not make any adjustment while the machine is running a cycle.



Disconnect pneumatic pressure before starting any adjustment task. Disconnect pressure by moving shut-off valve to the right.



TO PREVENT UNEXPECTED MOVEMENTS, ENSURE SLIDE VALVE IS CLOSED ONCE TASKS ARE DONE.

Press emergency stop button to isolate machine from pneumatic system.



Do not put your hand between any moving part of the machine. Do not make any adjustment while machine is running.



Do not leave unattended objects on the workstation to avoid risk of tripping or falling. Only those elements that are essential for carrying out the work must be in the work area.



DANGER

Ensure measures of all parts of the drawer match the adjustments made at the machine. Size of drawer elements as back, bottom, slide and other parts must be observed.

Do not force any element to fit into the machine, they could break and put operator at risk.

Stop the machine and check workbench and fixings if unusual vibrations, noises or movements are noticed.



Take regular breaks during the working day. Avoid forced postures while working with/on the machine.

9. SAFETY SYSTEM

The machine has been designed with an emergency stop button with latching function. Once this button is pressed, the machine stops and all elements return to initial position.

In order to restart normal activity, emergency button should be released.

On the left side of the machine there is a valve to isolate pneumatic pressure from facility net. Turn it clockwise to isolate the machine. Turn it to the left to activate the pneumatic connection and to restart the machine. Press emergency button previously.

To start a working cycle, press the two push buttons simultaneously at a maximum time delay of 0.5 seconds. They are connected to the security valve. It is mandatory to press these two push buttons during the complete cycle of the machine. If at any time only one button is kept pressed, the machine stops and elements return to initial position.

The start buttons (PM) are protected against accidental contact. Replace button guards if necessary as they are part of the machine safety's system.

Before putting the machine into operation ensure emergency button works properly by pressing it and unlocking afterwards. The machine does not work if only one start button is pressed.



DANGER

If by pressing only one start button the machine starts a cycle do not work on the machine. It presents a serious risk for the operator.

9.1. Time Delay Valve

The machine has been designed with a time delay valve which prevents from possible uncontrolled sudden movements. Elements which may not be a rest position when operator provides pressure will start a progressive movement to avoid risk for the operator.

Function of this valve is to provide a time delay until working pressure reaches the machine. Adjust time delay by using a screw located in the upper part of the valve.

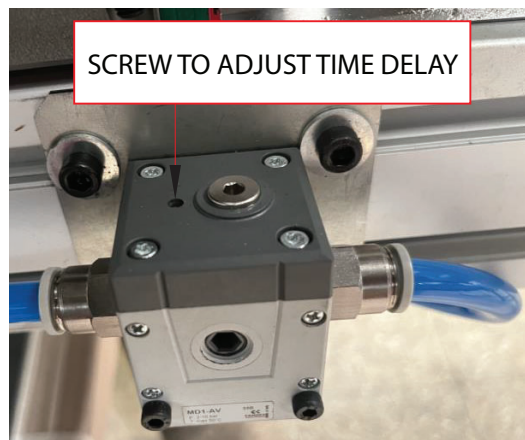
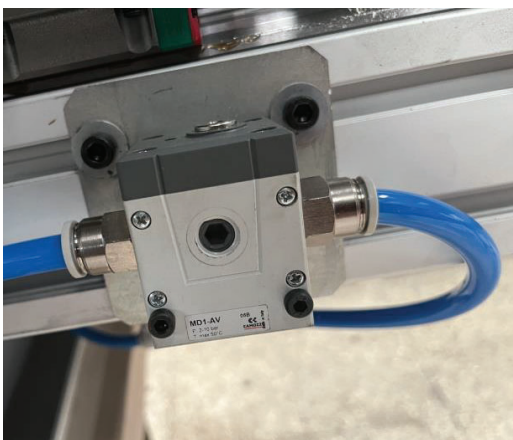

9.2. Stopper

Thanks to the stopper punches do not lower deeper than necessary which can lead to undesired holes or breaking the wood. It also prevents the punches from turning when producing drawers with small bottoms.



10. MAINTENANCE



Disconnect the machine from the pneumatic net before any maintenance activity.

Regular maintenance and timely replacement of worn or damaged parts increases the lifespan of the machine. Air conditions should be clean and dry. Humidity in the pneumatic installation shall have a strong negative effect on the machine and all pneumatic components. Even though the machine is equipped with a filter to remove impurities, an extra filter (not included) should be installed at the pneumatic inlet if air quality is deficient.



Only use the machine if pneumatic hoses are in good conditions. Do not start the machine and contact a qualified operator if they are not in good conditions as it entails serious risk for the operator. Replace protective equipment immediately at the first signs of damage.



Do not work on the machine if any of the described situations is observed. Using the machine under these circumstances involves serious risk for the operator. Contact authorized personnel to fix and repair all the issues.

Carry out prescribed setting, maintenance and inspection work in a timely manner.

Check the machine once a day or before each working shift:

- a. Check the function of safety and protection equipment. Verify they work properly. Check the emergency button remains locked after pressing it.
- b. Check pneumatic hoses and protective cover.
- c. Verify mechanical locking elements work properly (positioner, lever).
- d. Check stability of the machine on the workbench.
- e. Clean the machine at the end of every working shift

Every 40 hours or once a week:

- a. Verify mechanical elements are in perfect condition. Pay especial attention to the rolling and friction elements. In case any mechanical part shows unusual cracks or deformation, contact authorized personnel for them to replace them.
- b. Clean slides.

Every 100 hours or once a month:

- a. Check anchoring elements and mechanical fastening elements (positioner) and replace them if they do not work properly, get snagged or do not press correctly, regardless of how many hours have been used.
- b. Check there is no clearance in the drawer assembly element. Otherwise, replace guides and plain bearings. Verify this element moves uniformly. This movement shall never be abruptly.
- c. Verify there is not excessive play in the moving side part of the machine.
- d. Grease the skid. (See chapter Grease the Skids).
- e. Check there is no accumulated water in pneumatic filtering group.

Replace following parts every 500 working hours or once a year:

- a. The mechanical positioners of the machine. Pay attention to the nuts.
- b. Check the 4 screws fixing the machine to the workbench.
- c. Check the sealing (scraper) of the skids.
- d. Check the crimping elements.

Every 2,000 hours or every two years:

- a. Replace the crimping elements.
- b. Replace the filter of the pneumatic maintenance unit.

Replace following parts every 5,000 working hours or every 5 years:

- a. Rolling elements such as wheels, axles and other related parts.
- b. Skids.
- c. Pneumatic hoses and tube holder chains.
- d. Screws screws fixing the machine to the workbench.



DANGER

Do not work on the machine if any of the described situations is observed. Using the machine under these circumstances involves serious risk for the operator. Contact authorized personnel to fix and repair all the issues



DANGER

Do not confuse maintenance and repairing tasks. Only professionally qualified personnel shall be considered as a specialist and can assume repairing tasks.

10.1. Grease the Skids

To ensure the machine works correctly it is important to grease the sliding profiles. If this lubrication is not correct, the machine will not operate as intended and serious breakdown of the machine's mechanical system could occur.

There is a lubricating element located at one side of each skid. There are 10 skids and 10 lubricators in total distributed in the machine.

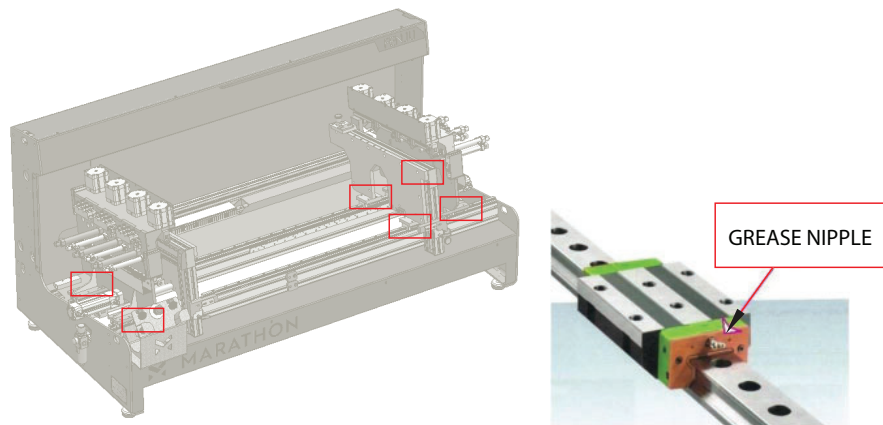

A grease pump (not supplied) provides lubrication and allows controlling the quantity. If too much grease is applied, sealing elements of the skids may break.

Recommended grease shall be similar to:

Kluber NBU-15
Beslux Plesbar L-2/S

10.2. Working Speed Adjustment

The machine is designed to receive the two elements that adjust the drawer at the same time. For this purpose, there are controllers located on the pneumatic press cylinders. Pneumatic press cylinders are protected by metallic guards.



Never operate the machine if the protective guards are not installed as they protect not only the cylinders but also prevent from reaching the dangerous part. Risk of hands being crushed while machine is in use.

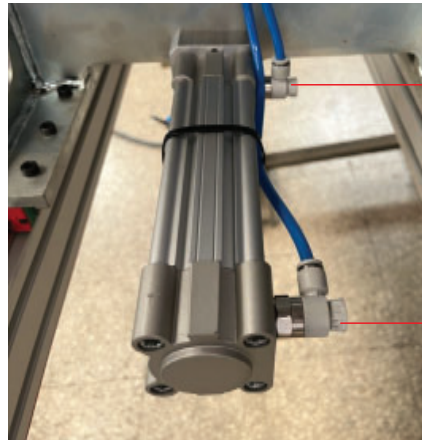

FORWARDS CONTROLLER

BACKWARDS CONTROLLER

Adjust movement speed by using feed controller so both elements act simultaneously.

10.3. Head Retreat Adjustment

In-line controller permits head retreat adjustment to avoid drawer sides hitting to



each and regular and progressive movements.



DANGER

Never work at less than 1.5 bar on pressure regulator. It holds the cylinder to the drawer sides and must be overcome by the cylinder placing punches to the right place in order to crimp the drawer. SDR valve should always work at 2 bar pressure.

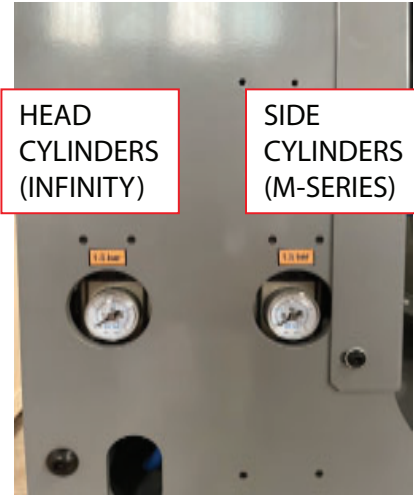

11. INSPECTION

12. APPENDIX

ATTENTION
WEIGHT: 485 Kg

DO NOT PILE!



APPENDIX I.

INFORMATIVE LABEL. PLACE IT ON THE MACHINE PACKAGING.

Use forklift or pallet truck to transport the machine inside the packaging.
Do not use lifting cranes or lifting systems that suspend the machine (inside the packaging) by means of cables, chains, ropes, straps...



DANGER

Take all feasible measures to minimize dangerous situations during transportation (inside the packaging), since there is a risk of crushing, cuts and torso injuries.

National regulations where the machine shall be manipulated and/or installed are binding.



APPENDIX II. RISK OF FINGERS AND HANDS BEING DRAWN WARNING SYMBOL

Warning symbol must be posted in a prominent location close to dangerous area in an obvious location for operators to read.

Observe safety regulation for occupational centers and premises UNE 81-501/81.

Warning symbols describe dangers and risks on working places.

APPENDIX III. CONTROLLER SIGNS

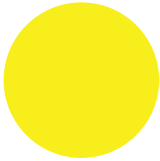
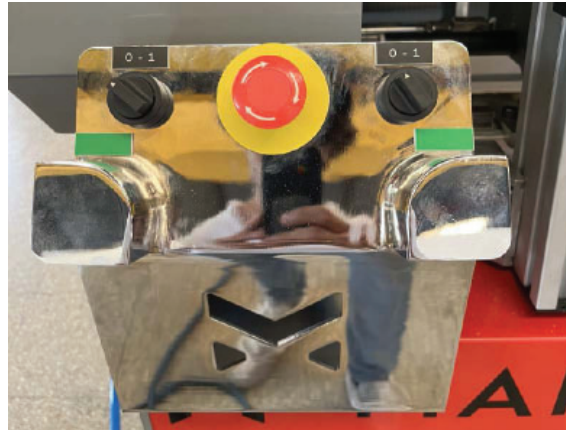

EMERGENCY CONTROLLER



SELECTOR SWITCH



TWO-HAND CONTROLLER



ON/OFF BUTTON

APPENDIX IV. SPARE PARTS AND ACCESORIES

Please find below a list of spare parts which may be necessary for normal use of the machine.

Be aware some spare parts or accessories must be installed by instructed personnel.



T slot nut T M5, profile 10 mm: ref: 52045



T slot nut M8, profile 10 mm: ref: 52048



T slot nut M6, profile 10 mm: ref: 52046



Guiding studs 301 retr 2 M-16. Ref: POS301

APPENDIX V. TWO-HAND CONTROLLER

Two-hand controller is a pneumatic AND module. P1 and P2 inputs must be pressed simultaneously with a maximum time delay of 0.5 seconds so that a pressure signal can be triggered at output A. This is done via two 3/2 valves with pushbutton. Air pressure is constant as long as both valves are pressed. If one of the valves (or both at the same time) are released, pressure output A stops immediately and system/machine signal will be discharged via port R.

The pneumatic two-hand control is designed to ensure that the operator has both hands out of the working area. Furthermore, it prevents unintentional operation once the work process has started.



TWO HAND SAFETY VALVE SERIES SAFE AIR®

The two hand safety valve generates an output signal only if two synchronised pneumatic input signals are received. If one input signal is interrupted, the output signal is interrupted as well. The most common application involves connecting a manual button-controlled valve to each of the inputs and using the output signal as a start-of-cycle control for a pneumatically-operated machine.

- The two hand safety valve can be secured with through screws or a DIN bar adaptor.
- The complete pushbutton panel includes the dual manual control valve, two manual pushbuttons, and an emergency stop valve, all housed in a metal box to be mounted on a wall or stand.
- The pushbutton housing is supplied on request for anyone wishing to get a personalised pneumatic connection or drill holes to secure the unit.

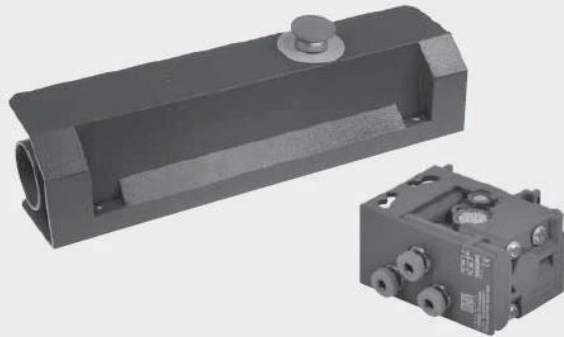

TECHNICAL DATA	
Compressed air couplings	mm
Fluid	Push-in fitting for Ø 4 pipe Filtered, unlubricated compressed air, max 50 µm
Version	Single-control – Complete pushbutton panel
Standard	<ul style="list-style-type: none"> • EN574 type IIIA, TÜV approved according to 2006/42/EC Certified TÜV-A-MHF/MG/13-05260 (code W3605000001) • Certified Bureau Veritas CV 003-12-2011 (code 0227700000)
Synchronisation, max. time between two signals	s
De-activation time, with pipe L = max 1000 mm	s
Actuation	0.4
Reset	< 0.05
Operating pressure	pneumatic
Temperature range	spring operated
Nominal diameter	2.5 to 8
Flow rate at 6 bar (0.6 Mpa - 87 psi) ΔP 1 bar (0.1MPa - 1.45 psi)	- 10 to +60
Mounting position	2.7
	85
	In any direction

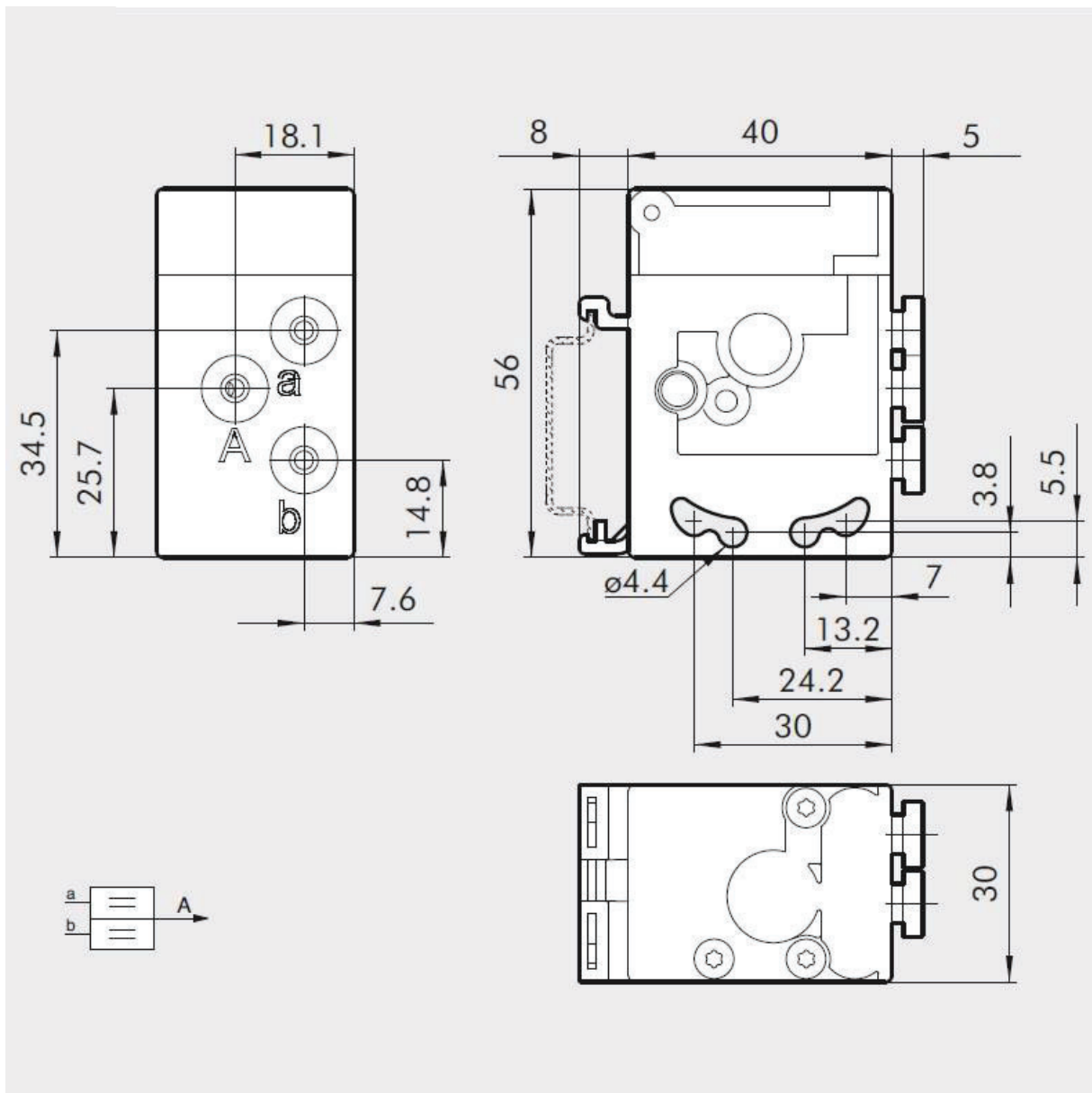

APPENDIX VI. SOFT START VALVE

A soft start valve is installed.

- Safety function as it maintains sequence correctly
- Opening the main air circulation at 50% of inlet pressure value

Soft start valves prevent abrupt movements of pneumatic elements. Pneumatic input is enough to start the gradual increase of pressure provided to the system. Thanks to a regulating screw it is possible to adjust the time a valve needs to reach 50% of the inlet pressure. Once this value is reached, the valve opens completely to allow free circulation.



MARATHON

H A R D W A R E

info@marathonhardware.com

800.840.1228

marathonhardware.com

