

Metalbox Drawer System

Technical Specifications & Assembly

Metal Box Drawer System 86mm Height Sides



Product Features:

- Epoxy Finish: White
- Self-Closing
- Double stop positions
- 2-D front
- Screw-on bottom panel
- Lengths: 270-550mm
- Load capacity: 25kg

Metal Box Drawer Kit Included Parts

- One pair of Full Extension Metal Side Rails
- One pair of Metal Box Sides 86mm Height

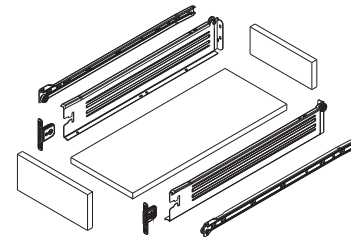

Metal Box Drawer Kit

Length (mm)	Side Height	Colour	Part#
270mm	86mm	White	105-F12E-270
300mm	86mm	White	105-F12E-300
350mm	86mm	White	105-F12E-350
400mm	86mm	White	105-F12E-400
450mm	86mm	White	105-F12E-450
500mm	86mm	White	105-F12E-500
550mm	86mm	White	105-F12E-550

Front Fixing Brackets for 86/150mm Sides

Mounting	Part#
Screw-On	105-L1M
10mm Dowels	105-L1MM
10mm Expansion Dowels	105-L2MC

Lateral Rail System	
Length	Part#
350mm	105-HY350
400mm	105-HY400
450mm	105-HY450
500mm	105-HY500
550mm	105-HY550

Product Marking Jig

Description	Part#
Marking Jig for 86mm/150mm Metal Box Drawer System	105-A3M1



Space Requirements

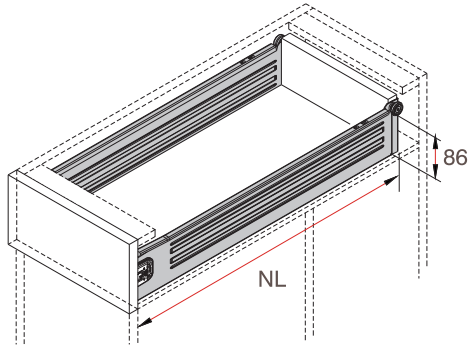

Installation Dimensions

Cabinet depth(Cmin)=Nominal length+3

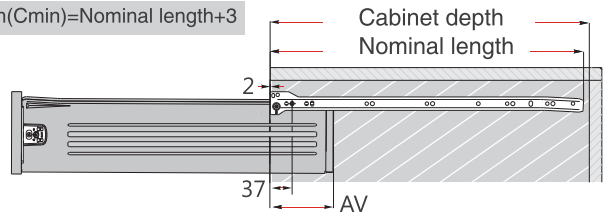

Installation Dimensions

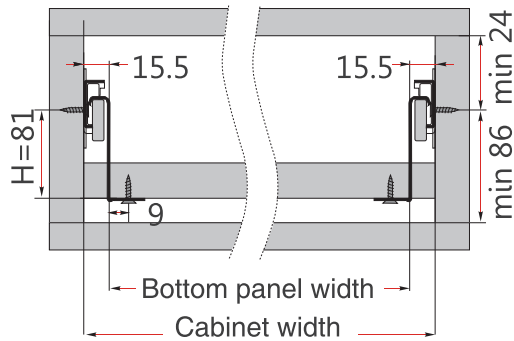

Drilling Pattern

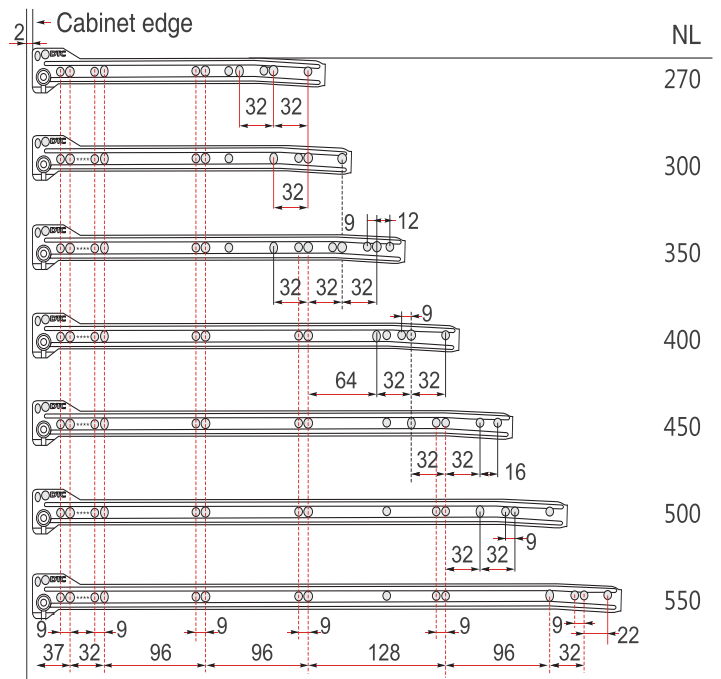

Front, Back Dimension

Front Connector

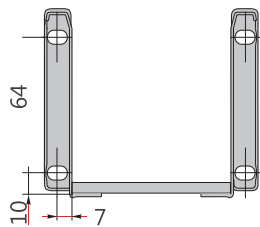

Back

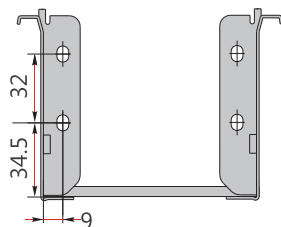

Adjustment

