

LEGACY Drawer System

Specifications & Ordering Guide

Internal Drawer With High Glass Front, 172mm C Height

Product Features



- Modern Straight Slim box drawer system
- Silent system guarantees quiet, smooth run
- High dynamic load capacity: 40/60kg (88/132lbs)
- Concealed slide with full extension
- Tool free assembly and removal of drawer
- 3D Adjustment

To make this unit, order Standard Drawer plus parts listed below

Order Standard Drawer Kit with 172mm C height sides plus these parts:

- One pair of internal front fixing brackets for use with short height internal drawer fronts and glass
- One short height colour-matched 1100mm length metal internal drawer front, which can be cut to match your drawer width
- One tall height glass front according to width of your cabinet

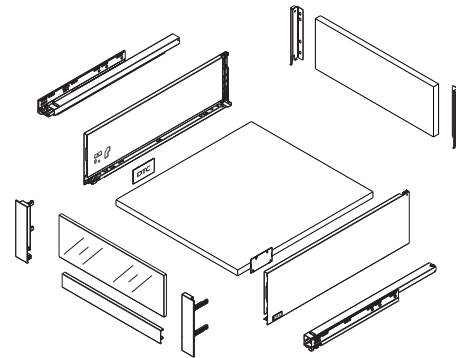

Internal Drawer Short Height Glass Fronts

Internal Drawer Short Height Glass Fronts

Length	Part#	Qty.
300mm	105-HG132-GL300	10
350mm	105-HG132-GL350	10
400mm	105-HG132-GL400	10
450mm	105-HG132-GL450	10
500mm	105-HG132-GL500	10
600mm	105-HG132-GL600	10
800mm	105-HG132-GL800	10
900mm	105-HG132-GL900	10
1000mm	105-HG132-GL1000	10
1200mm	105-HG132-GL1200	10

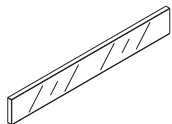

Finish	Part#	Qty.
Matte Grey	105-HT13013-GM	60
Silk White	105-HT13013-SW	60

Finish	Part#	Qty.
Matte Grey	105-HT10021-GM	60
Silk White	105-HT10021-SW	60

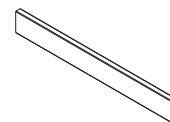
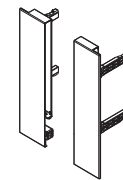

LEGACY Drawer System

Specifications & Ordering Guide

Space Requirements

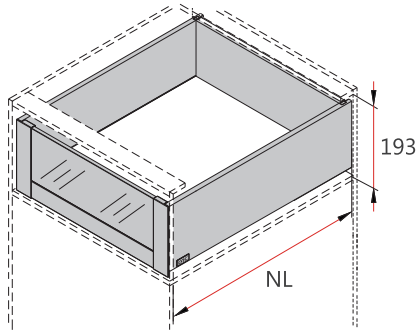

Installation Dimensions

NL=Nominal Slide Length
 LT=Internal Cabinet Depth
 LT=NL+3

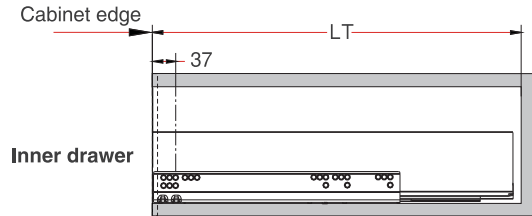

Installation Dimensions

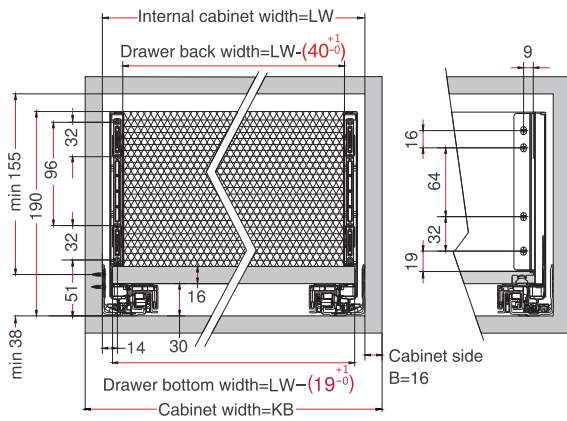

Drilling Pattern

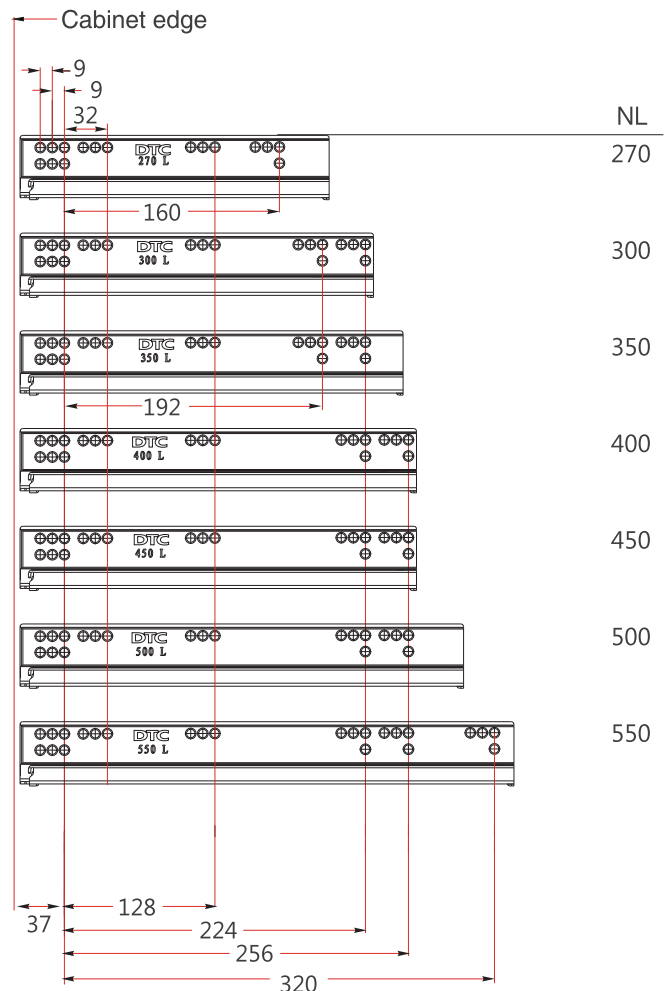

Drawer Front, Back and Bottom Dimension

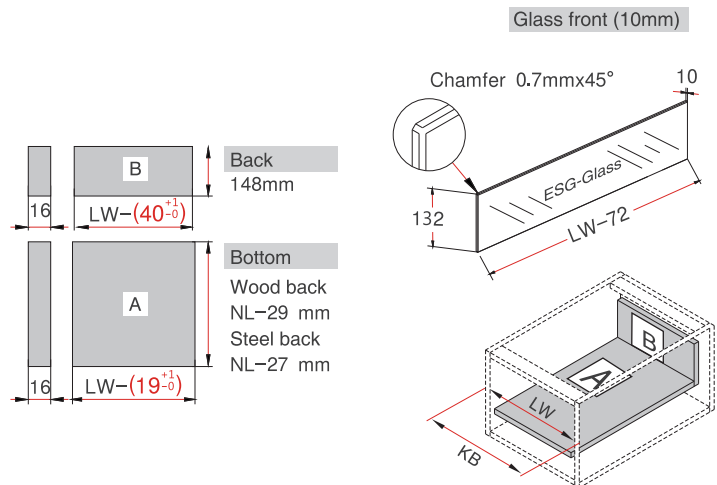

KB = Cabinet Width
 LW = Internal Cabinet Width
 NL = Nominal Slide Length