

Quick Tech mock up

Part Number: IFY0DU030101



Quick Tech Worktop Connector Mock-Up

Quick Tech is brilliantly engineered to effortlessly lock two worktops or panels together with flawless precision.

Application Type ----- Connectors

Product Description

QUICK TECH is designed to join two worktops or panels together, consisting of two components: a main body with tightening dowel M8x64, M8x100 or M8x150 and a round cap to suit the dowel head.

The installation is fast and easy when using an S6mm allen wrench, or cordless driver. It is suitable for worktops and panels that are a minimum of 25mm thick.

Product Advantages

- Press-fit positioning, reduced risk of parts falling during installation, enhancing efficiency.
- Compatible with S6 mm Allen wrench or cordless driver.
- Suitable for worktops and panels minimum 25 mm thick.



Technical Documents



View this product online at <https://marathonhardware.com/pd/IFY0DUJ030101>

Technical Documents

QUICK TECH

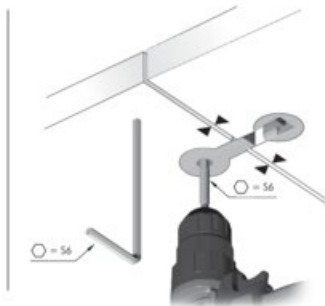
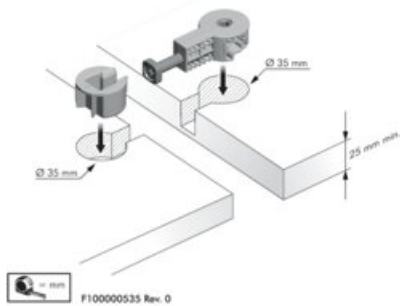
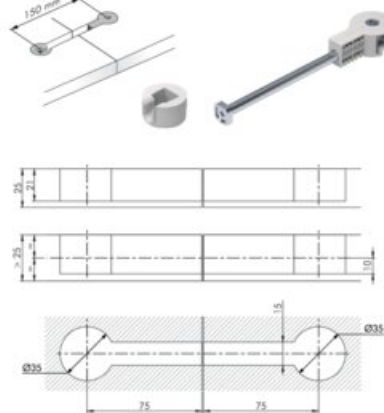
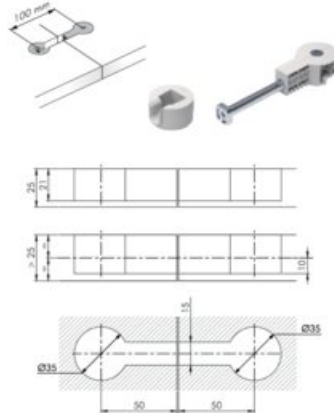
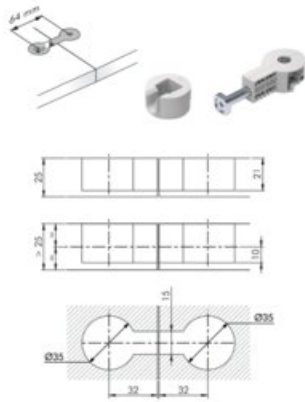

View this product online at <https://marathonhardware.com/pd/IFY0DU030101>

